



Sk II India
कौशल भारत-कुशल भारत



सत्यमेव जयते
GOVERNMENT OF INDIA
MINISTRY OF SKILL DEVELOPMENT
& ENTREPRENEURSHIP



N S D C
National
Skill Development
Corporation

Transforming the skill landscape



Facilitator Guide

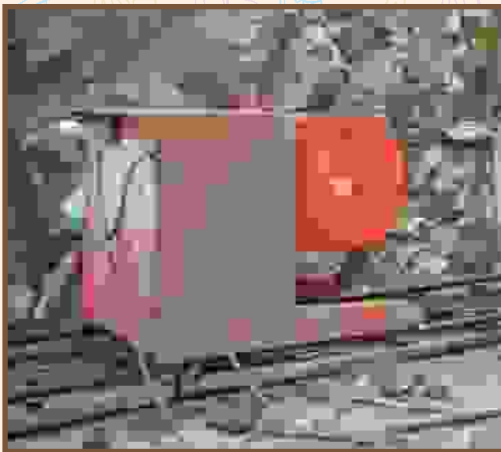

Sector
Mining

Sub-Sector
Mining Operations

Occupation
Drilling / Cutting

Reference ID: MIN/Q0203, Version 1.0
NSQF Level: 4

Wire Saw Operator



Shri Narendra Modi
Prime Minister of India

“ Skilling is building a better India.
If we have to move India towards
development then Skill Development
should be our mission. ”

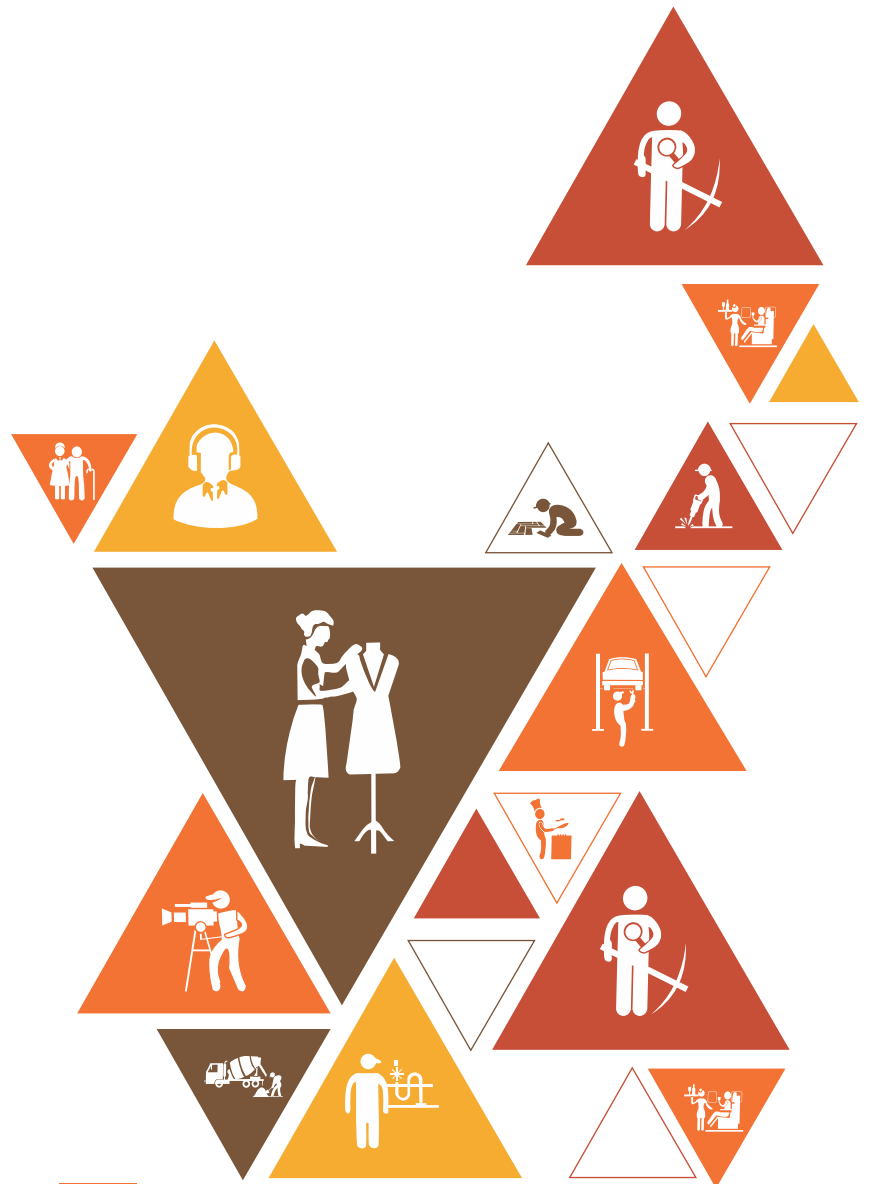

Acknowledgements

Skill Council for mining Sector (SCMS) has become operational since January, 2014 with a mandate to support the mining sector through a range of skill development initiatives that includes development of National Occupational Standards and Qualification Packs (NOS/QP) for job roles in line with National Skill Qualification Framework (NSQF) in PPP mode. SCMS has carried out occupational mapping and skill gap study for sector. The skill development programmes (both for opencast and underground mines) are carried through its Accredited Training Providers to ensure adequate availability of skilled manpower. The workers are certified by SCMS after third party assessment.

The key factors affecting human resources and skill development in Indian Mining Industry are technology up gradation, health and safety at work place, trend for using advanced and high capacity machinery, stringent environment and sustainable development framework and aging profile of workforce.

Considering the specialization and complexity of job roles in mining sector, a systematic and analytical approach was required for development of contents corresponding to specified to QP/NOS in line with the guidelines of NSQF. Accordingly taking benefit of the available in-house competency along with support of domain experts, SCMS has developed this “**Facilitator Guide**” for **Wire Saw Operator**.

I, gratefully acknowledge the support and contribution received from various mining companies in the development of QP and NOSs for the job roles. I am sure that this Guide will be helpful for the trainees, trainers, assessors and other stakeholders. I wish to place on record our appreciation for the contribution made by entire team of SCMS and the support extended by NSDC team.

It is expected that this publication would meet the requirement of QP/NOS based training delivery for the job role of **Wire Saw Operator**. However, suggestions from users, mining companies, experts and other stakeholders for improvements are welcome.

17th May 2016
New Delhi

A.K. Bhndari
Chief Executive Officer

About this Guide

Cutting or drilling is an important function in any mining operation, especially surface mining. This Facilitator Guide is based on Wire Saw Operator Qualification Pack (MIN/Q0203) and includes the following National Occupational Standards (NOSs):

1. MIN/N 0209 (Prepare Wire saw)
2. MIN/N 0210 (Perform Wire saw Operations)
3. MIN/N 0211 (Carry Out Reporting and Logging – Wire Saw Operator)
4. MIN/N 0204 (Health and Safety)

Individuals at this job operate a Wire saw machine which is used to cut large blocks of stone out from the marble quarry. Wire saws are large machines that use diamond-impregnated beads on a cable to cut through marble, granite and other similar rocks. Wire saw is also used for squaring of the cut slab into square shaped blocks before transporting to the production plant.

Operating a Wire saw is a specialized task that can be safely performed only with adequate training and experience. Wire saw operators are also responsible to ensure basic upkeep of the machine and safety in operations.

Post this training, the participant will be able to drive and operate a wire saw machine which is a large machine used to cut large blocks of stone out from the marble.

We hope that this Facilitator Guide will provide a sound teaching support to our trainers to teach students of the Mining industry.

Symbols Used



Steps



Time



Tips



Notes



Objectives



Do



Ask



Explain



Elaborate



Field Visit



Practical



Lab



Demonstrate



Exercise



Team Activity



Facilitation Notes



Learning Outcomes



Say



Resources



Activity



Summary



Role Play



Example

Table of Contents

S.No	Modules and Units	Page No
1.	Introduction	1
	Unit 1.1- Getting Familiarized	3
	Unit 1.2- Introduction to Mining Industry	6
	Unit 1.3- Mining Methods	14
	Unit 1.4- Stone Mining in India	23
	Unit 1.5- Mining Equipment	33
	Unit 1.6- Duties and Responsibilities of a Wire Saw Operator	46
2.	Prepare the Wire Saw (MIN/N0209)	51
	Unit 2.1- The Wire Saw Machine and Its Parts	53
	Unit 2.2- Preparing the Wire Saw Machine for Operation	73
3.	Perform the Wire Saw Operation (MIN/N0210)	81
	Unit 3.1- Understanding Operation Standards	83
	Unit 3.2- Do's and Don'ts of Wire Saw Operation	91
	Unit 3.3- Operating Instructions	97
	Unit 3.4- Typical Issues and Troubleshooting	103
	Unit 3.5- Enhancing Productivity	111
	Unit 3.6- Ensuring Safety	116
4.	Carrying Out Reporting and Logging - Wire Saw Operator (MIN/N0211)	123
	Unit 4.1- Documenting Daily Activities	125
	Unit 4.2- Organisational Guidelines and Reporting Procedures	131
5.	Housekeeping (MIN/N0204)	139
	Unit 5.1- Need for health, Safety and Security at workplace	141
	Unit 5.2- Hazards of Mining	148
	Unit 5.3- Mine Safety equipment	156
	Unit 5.4- Fire Safety and First Aid	159
6.	Employability & Entrepreneurship skills	179
	Unit 6.1- Personal Strengths & Value Systems	181
	Unit 6.2- Digital Literacy: A Recap	183



S.No	Modules and Units	Page No
	Unit 6.3- Money Matters	184
	Unit 6.4- Preparing for Employment & Self Employment	185
	Unit 6.5- Understanding Entrepreneurship Unit	186
	Unit 6.6- Preparing to be an Entrepreneur	188
7.	Annexures	191
	Annexure I :	192
	Annexure II:	207



Skil India
कौशल भारत-कुशल भारत



सत्यमेव जयते
GOVERNMENT OF INDIA
MINISTRY OF SKILL DEVELOPMENT
& ENTREPRENEURSHIP



N · S · D · C
National
Skill Development
Corporation

Transforming the skill landscape



1. Introduction

Unit 1.1 - Getting Familiarized

Unit 1.2 - Introduction to Mining Industry

Unit 1.3 - Mining Methods

Unit 1.4 - Stone Mining in India

Unit 1.5 - Mining Equipment

Unit 1.6 - Duties and Responsibilities of a Wire Saw
Operator

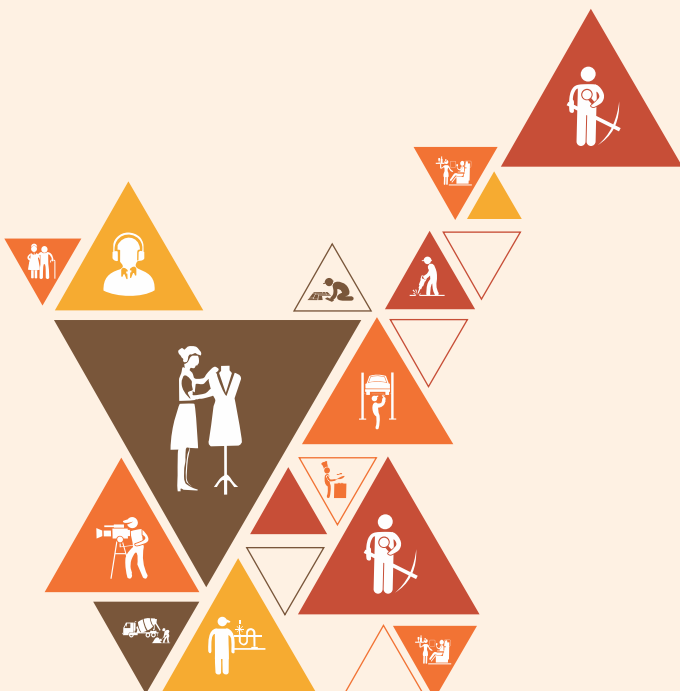

Key Learning Outcomes

At the end of this module, you will be able to:

1. Explain the key features of the Indian mining sector
2. Discuss various mining methods
3. Discuss the various phases and types of mining
4. Elaborate on the process and regions of marble and granite mining in India
5. List the various mining equipment and the precautions necessary to use them
6. Explain some basic electrical concepts
7. List the duties, responsibilities and key competencies of a wire saw operator

UNIT 1.1: Getting Familiarized

Unit Objectives

At the end of this unit, you will be able to:

1. Get introduction of students
2. Build rapport with students
3. Create Rules for class

Resources to be Used

- White Board + Marker /Black Board + Chalk
- Duster
- Laptop + Projector / Computer + Projector / Flipcharts
- Participant Handbook / Copies of Handout

Notes for Facilitation

- Start the first session with very high energy
- Be ready with course curriculum
- Make list of benefit from the course for students
- It would be good if you have some success stories of previous batch students, it will create enthusiasm in new students
- Make list of expectation from students
- Prepare some questions related to the job roles for asking from students for generating curiosity, for example – Ask student if they know for what purpose Wire Saw is used?
- Be ready for answering any question related to the job role, you should feeling to students that you have authority over the subject.
- Ensure all the resources, such as white board, marker or projector is in working condition before students arrive.
- Create some Wire Saw related stories to start the session for making the first session interesting and engaging.
- Arrive early in class before students.
- Start class on time and close the session on time, so that you can give clear message of valuing your and students time.

Do

- Make the small circle of students.
- Welcome all the participants and appreciate them for choosing this course.

- Introduce yourself with your name, qualification and work experience.
- Give details of Objectives of this course.
- Give details of today's session and what they are going to learn.
- Give Safety Instructions during class.
- Brief them about the rules of class and Do's and Don'ts.
- Encourage them to share their thoughts and doubts now and during process of this course.

Ask



- Ask all students to introduce themselves.
- Ask their expectation from the course.

Notes for Facilitation



- Make rules for class, for ex-
 - All student will come on time
 - In case of leave student will inform atleast a day in advance
 - No talk over mobile will be allowed in class
 - Mobile will always be in silent / switch off mode in class
 - No gossip in class
 - Any break in class will be with trainer permission only
 - If any student wants to say anything, he/she will raise his/her hand. He / she will only speak when trainer ask for it.
- You can add any other rules, which will increase effectiveness of training.
- Objective of this Program is that after completing the course the student will be able –
 - Understand requirement of skilled work force for making strong India
 - Discuss about related Sector and Sub Sector
 - Describe the job role in detail
 - Perform all the responsibilities of job role
 - Get developed as a job ready person
 - Get recognized certificate for acquired skill
 - To get job in related industry based on certificate received after completing the course.
- Some of the Roles and Responsibilities of Trainer –
 - To provide training as per QP and NOS defined.
 - To clear all doubts of students, related to job role during training
 - To create required discipline in class
 - To ensure health and safety of all students during class training and field visits
 - Provide maximum practical exposure to students for job role

Say



- Thank the students for their participation.
- Inform them rules of the class

- Inform them about course curriculum.
- Inform them about assessment and assessment procedure.
- Inform them about your Role and responsibility.

Notes for Facilitation

- To know students better, you can ask their hobbies, the sport they like, the sportsperson or film star they like. It will help you open them up and create some bonding.
- Learn their name, this is very important in order to have feeling of connectivity.
- Create your own rules for class. Rules should be flexible, still ensure discipline in the class.
- It is necessary to let students know about assessment procedure so that they do study in line with that and assessment should not come as a surprise.
- Anticipate questions from new students and prepare in advance.
- You can also inform them about PMKY, Skill India mission and NSDC, so that they feel connected to a bigger cause of nation building.
- Create your own notes for improvement in next session.
- If students appear bored then have some activity in class.
- Stay organised in class, student give respect to organised teachers.
- Use variety of teaching techniques, so that you can engage all the students.
- Set high but realistic expectation from students.

Activity

- Conduct a familiarization activity.
- Ask the students to make group of 5 students.
- Explain the purpose and duration of the activity

Activity	Time	Resources
Introduction to team, sharing of contact details so that every student has minimum 4 contacts in class, which help them in case they are absent from class and other help	2 hours	Notebook, pen

UNIT 1.2: Introduction to Mining Sector

Unit Objectives

At the end of this unit, students will be able to:

1. Describe the mining industry in India
2. Describe the growth expected in the mining industry
3. Explain the various kinds of minerals available in various parts of India
4. Describe the key workforce requirement in the mining sector
5. List various mining acts, legislation and key bodies in India

1.2.1: The Mining Industry

Resources to be Used

- Laptop
- Projector
- White Board
- Marker
- Duster
- Sample of different Minerals
- Field visit to Marble Mine
- Details and photos of Different machines used in Mining
- Maps and photos of Mining Areas

Do

- Greet the participants for the day.
- Give Summary of previous Session.
- Ask for any doubts in previous Session.
- Acknowledge for their doubt-raising, if any. Clear the doubts.
- Give details of today's session and what they are going to learn.
- Encourage them to share their thoughts and doubts now and during process of this course.

Ask

- Ask students what they know Wire Saw.
- Ask students about Different types of Mines.



Fig. 1.2.1. Mining

Say

Minerals are valuable natural resources. They are available in limited quantities on Earth. They provide the raw materials for many basic industries and are a major resource for our development.

Mining and mineral extraction in India go back to ancient times. The wide availability of the minerals in India in the form of abundant rich reserves made it very conducive for the growth and development of the mining sector in India. The following shows mining operations in progress.

India has huge resources of many metallic and non-metallic minerals and mining remained a key sector since India's independence. India produces as many as 87 minerals, including:

- 4 Fuel
- 10 metallic minerals
- 47 non-metallic minerals
- 3 atomic minerals
- 23 minor minerals (including building and other materials)

Notes for Facilitation

- You could ask the students what they know about Mining and product made from mining.
- Give students some time to think about how the Mining industry has grown in the last five years.
- Set the context and describe the industry trends in Mining.

1.2.2: Growth of Mining Industry

Ask

- Ask students whether they seen the Mining.
- Ask students about places where Mining is done.

Explain

Overall, mineral production in India has been growing. The Indian Mining sector registered a growth of 2.6% during the 9 year period 2004-05 to 2013-14 and contributed approximately 1.9% (1.07 lakh crore) to the national GDP.

The Indian mining industry is characterized by a large number of small operational mines. These include mines for mineral production, minor minerals, petroleum (Crude), natural gas and atomic minerals and others. The states which have the most number of mines includes the following as shown in the following figures:

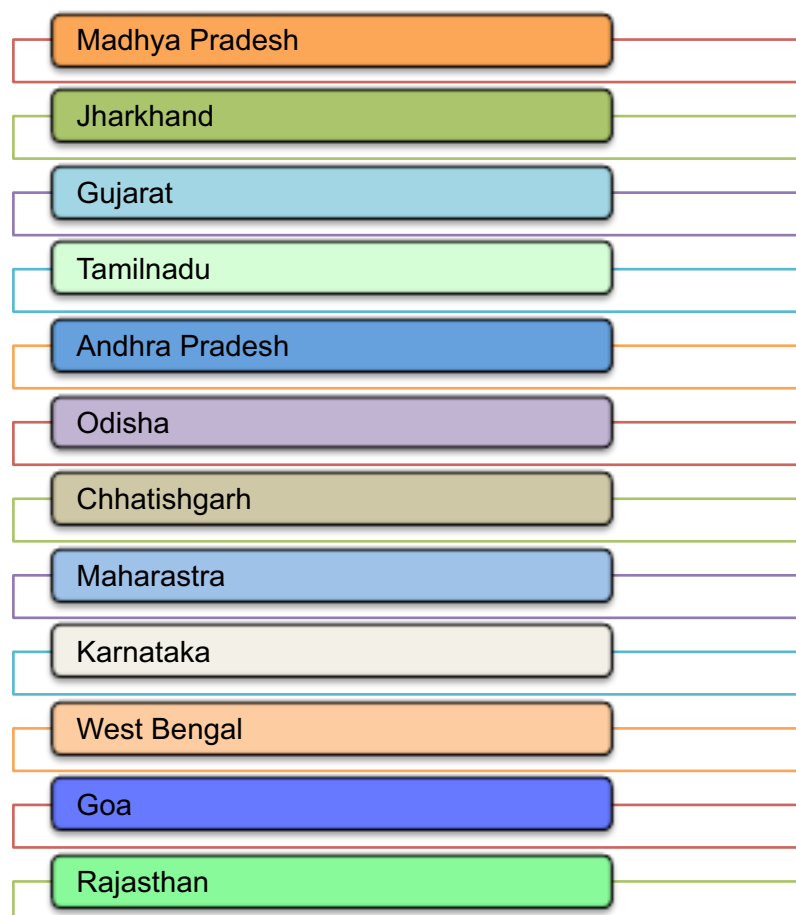

Fig. 1.2.2. The key mining states in India

These 12 states together accounted for 95% of total number of mines in the country in 2015-16.

The major strength of the mining sector in India include following:

1. Vast availability of mineral deposit: India currently produces 89 minerals
2. **High Production of mineral and metal together:** In 2012, India ranked 3rd in the world in production of coal, lignite and Chromite production, 5th in iron ore, 6th in Bauxite; in terms of metal production, the country ranked 3rd in Zinc (slab) and 4th in Steel (crude/liquid) Production.
3. **Self-sufficiency in key minerals for domestic consumption:** India is wholly self-sufficient in minerals such as Bauxite, Chromite, Limestone, Zinc etc.
4. **Beneficial Policy / regulatory frameworks for the mineral sector:** Various polices for exploration , mining, mineral processing and metallurgy for all non-fuel and atomic minerals encourage growth of the mining sector in India.
5. **Availability of financial incentives:** These include concessions on export profits from specified minerals and ores, which further encourage mining.

Demonstrate

- Show Maps with Mining Areas.
- Show Photographs / Video of Mining Process.

1.2.3: Minerals in India

Ask

- What is Mineral.
- Which are the minerals found in India.

Explain

The following figure indicates the key mines in India and their location in various states of India:

Mineral	States	Mineral	States
Asbestos	Andhra Pradesh	Iron Ore	Andhra Pradesh
	Odisha		Chattishgarh
Bauxite	Chattishgarh		Goa
	Goa		Jharkhand
	Gujarat		Karnataka
	Jharkhand		Kerala
	Karnataka		Madhya Pradesh
	Kerala		Maharashtra
	Madhya Pradesh		Odisha
Odisha	Rajsthan		
Chromite	Tamilnadu	Lead & Zinc	Andhra Pradesh
	Karnataka		Madhya Pradesh
	Maharashtra		Odisha
	Manipur	Rajsthan	
	Odisha	Maganese Ore	Andhra Pradesh
Copper Ore	Gujarat		Goa
	Jharkhand		Gujarat
Karnataka	Karnataka		
Madhya Pradesh	Madhya Pradesh		
Rajsthan	Maharashtra		
Sikkim	Odisha		
Diamond	Madhya Pradesh	Rajsthan	
Gold	Andhra Pradesh	Ruby*	Karnataka
	Jharkhand	Odisha	
	Karnataka	Sappire*	Jammu & Kashmir
	Rajsthan		

* Precious Stone

Fig. 1.2.3. The key minerals in India

The Indian mining sector employed approximately 23.25 lakh people in 2011-12 across the organised and unorganised sector (including self-employed). The estimated demand in mining sector over the period 2014-22 is anticipated to be approximately 2.59 lakh people.

1.2.4: Mining Acts and Legislation

Explain



The Government of India has multiple legal provisions and laws to protect the rights of mine workers and ensure proper mining processes and procedures.

1.2.4.1: The Mining Act, 1952

Elaborate



The Mines Act, 1952 is a Central Government Act. The following figure shows the provision defined by the Mine Act, 1952:

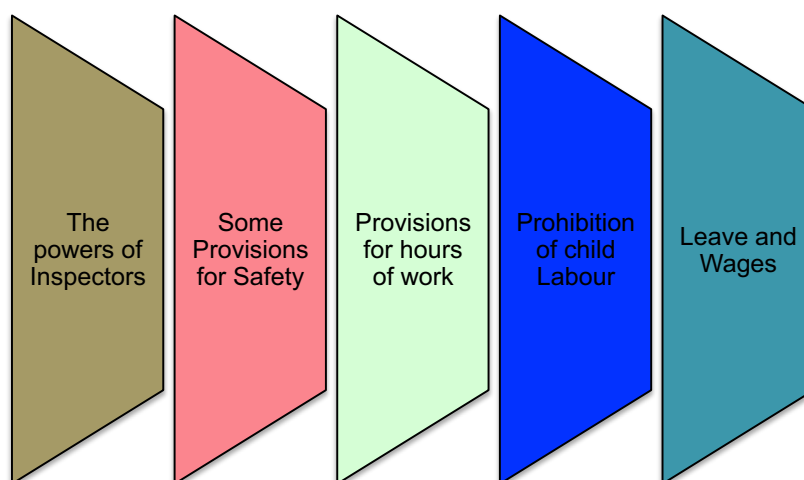

Fig. 1.2.4. Provisions in the mines act

The Mines Act {Section 2 (I)} defines a mine as “any excavation where any operation for the purpose of searching for or obtaining minerals has been or is being carried on and includes:

- i. All borings, bore holes, oil wells and accessory crude conditioning plants, including the pipe conveying mineral oil within the oilfields.
- ii. All shafts, in or adjacent to and belonging to a mine, where in the course of being sunk or not.
- iii. All levels and inclined planes in the course of being driven;
- iv. All opencast workings.
- v. All conveyors or aerial ropeways provided for the bringing into or removal from a mine of minerals or other articles or for the removal of refuse therefrom.
- vi. All adits, levels, planes, machinery works, railways, tramways and sidings in or adjacent to and belonging to a mine.
- vii. All Protective works being carried out in or adjacent to a mine.
- viii. All workshop and store situated within the precincts of a mine and the same management and used primarily for the purpose connected with that mine or a number of mines under the same management.

ix. all power stations, transformer sub-stations converter stations, rectifier stations and accumulator storage stations for supplying electricity solely or mainly for the purpose of working the mine or a number under the same management;

x. any premises for the time being used for depositing sand or other material for use in a mine or for depositing refuse from a mine or in which any operations in connection with such and refuse or other material is being carried on, being premises exclusively occupied by the owner of the mine.

1.2.4.2: Mine Rescue Rules

Explain



The mine Rescue rules, 1985 were framed in order to provide for rescue of worker in the event of explosion, fire etc. in mines. These apply to coal and metalliferous underground mines. The rescue Rules provide for the establishment of rescue stations and conduct of rescue work in mines affected by an explosion or fire, an inrush of water or influx of gases to operate under these conditions, services of specially trained men with special rescue apparatuses are required.

1.2.4.3: Directorate General of Mines Safety (DGMS)

Explain



The Directorate General of Mines Safety, DGMS in short, is a Regulatory Agency under the Ministry of labour and employment, Government of India. The responsibility for enforcement of occupational safety, health provisions and welfare of workers in mines, as provided in the Mines Act with the Directorate General of Mines Safety (DGMS).

1.2.4.4: International Labour Organization (ILO) and World Health Organization (WHO) Standards

Explain



The ILO and WHO have a common definition of occupational health of employees. they recommend that organisations are required to provide a healthy, safe and secure working environment for the following causes as shown in the following figure:

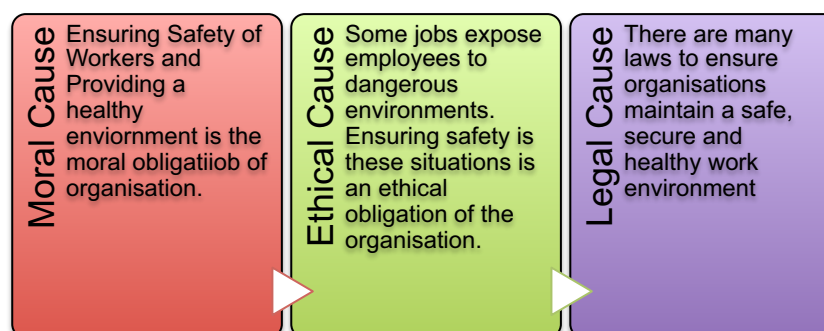

Fig. 1.2.5. Causes for organisations to ensure a safe and healthy work environment

The main focus in occupational health is in three different objectives:

1. The maintenance and promotion of worker's health and working capacity.
2. The improvement of working environment and work to become conducive to safety and health.
3. The development of work organisations and working cultures in direction which supports health and safety at work, and in doing so also promotes a positive social climate and smooth operations, and may enhance productivity of the undertakings.

Working culture here means a set of essential value systems adopted by an organisation to ensure a healthy and safe environment to its employees by improving its managerial systems, personnel policy, principles for participation, training policies and quality management systems.

1.2.4.5: Indian Bureau of Mines (IBM)

Explain



IBM is the principal governing agency responsible for compiling exploration data and mineral maps, and for providing latest information regarding mineral resources in India.

1.2.4.6: Department of Mines and Geology

Explain



The Department of Mines is responsible for survey and exploration of all minerals (other than natural gas and petroleum) for mining and administration of the Mines and Minerals and (Development and Regulation) Act, 1957, in respect of all mines and minerals, other than coal, natural gas and petroleum.

1.2.4.7: Geology Survey of India (GSI)

Explain



The GSI is the key agency for assessment of geological and regional mineral resources in India. It was established in 1851.

1.2.4.8: Central Mine Planning & Design Institute Limited

Explain



Central Mine Planning & Design Institute Limited (CMPDI) is a Government of India enterprise having its corporate headquarters at Ranchi in India. It is fully owned subsidiary of Coal India Limited (CIL). The function of CMPDI is the consultancy and support for mineral exploration, mining, infrastructure engineering, environmental management, and management systems, especially to the mineral, mining and allied sectors.

1.2.4.9: The Marble Development and Conversion Rule, 2002

Explain

These rules cover the conservation, systematic development and scientific mining to conserve the marble resources in India, and to provide a uniform framework for systematic and scientific exploitation of marble in India. It also provides provisions for employment in mines and adopting environment-friendly mining methods.

There are several other bodies and laws which ensure smooth operation of mining activities in India.

1.2.4.10: Skill Council of Mining Sector (SCMS)

Explain

The Skill Council for Mining Sector (SCMS), promoted by the federation of Indian Mineral Industries (FIMI) and supported by Ministry of Mines, was established to develop skill competency standards and qualifications in Mining sector, benchmark it with national and international standards and to work with the mining industry.

SCMS aims at training and up-skilling approximately 4.50 lakh people for mining industry including 50 thousand new inductees to make them employable within a period of 10 years.

Activity

- Conduct a 'State and Mineral activity'.
- Ask the students to make group of 5 students.
- Students have to Create Groups of Mineral along with state.
- One group of Students will have 30 minutes for creating presentation. 10 minutes for presentation.
- Appreciate identification skill of students and tell correct mineral found in state, if any mineral is wrongly quoted.

Activity	Time	Resources
State and Mineral activity	2 Hours	Participant Handbook, Notebook, pen, Flipchart / Laptop, Map of India and Rajasthan

Field Visit

- Field visit to mine site.

UNIT 1.3: Mining Methods

Unit Objectives

At the end of this unit, students will be able to:

1. Explain the difference between minerals, rocks and ores and categories of minerals
2. Discuss various types of mines
3. Explain the various phases in mining
4. List some key mining terms and definitions

Resources to be Used

- Laptop
- Projector
- White Board
- Marker
- Duster
- Sample of different Minerals including Artificial Minerals
- Field visit to Marble Mine
- Details and photos of Different machines used in Mining
- Photos of different types of Mining Methods

Do

- Greet the participants for the day.
- Give Summary of previous Session.
- Ask for any doubts in previous Session.
- Acknowledge for their doubt-raising, if any. Clear the doubts.
- Give details of today's session and what they are going to learn.
- Encourage them to share their thoughts and doubts now and during process of this course.

1.3.1: Mining Basics

Ask

- What are Mineral?
- How Minerals formed?

Explain

- **Minerals:** Naturally occurring chemical elements. The following shows examples of minerals.



Fig. 1.3.1. Minerals

- **Rocks:** Compounds of minerals. The following shows the process of forming rocks.

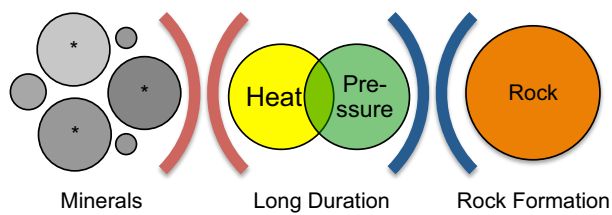

Fig. 1.3.2 Formation of rocks



Fig. 1.3.3 Example of Rock

- **Ores:** Rocks containing minerals or metals which can be recovered and used as resources. The following shows the process of forming ores.

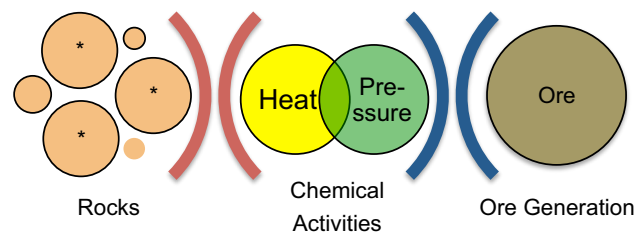

Fig. 1.3.4 Formation of ores

The following picture shows examples of ore.



Fig. 1.3.5 Example of Ores

- **Artificial Minerals:** Created by people in industries. These are not technically minerals but are treated similarly during processing in factories. The following show some examples of artificial minerals.



Fig. 1.3.6 Example of artificial minerals

1.3.2: Types of Mine

Ask



- What is the basis of classification of Mines?
- What are the types of Mines?

Explain



Mining operations can broadly fall under one of the below two categories:

- Surface Mining
- Underground Mining

1.3.2.1: Surface Mining

Explain



Surface mining is conducted on the surface of the ground. Surface mining can be of the following kinds:

Open-Pit Mining

Open-pit mining is a type of strip mining in which the ore deposit extends very deep in the ground. Here, the top layer of overburden is removed leaving a large pit to extract deposits such as coal. following picture shows an open-pit mine.



Fig. 1.3.7 Open pit mine

Strip Mining

Here, the overburden is stripped and placed onto an area which has already been mined out. The following shows strip mining.



Fig. 1.3.8 Strip mining

Quarrying/Cutting

This is an open-pit mine to extract stones or rocks such as marble or granite. The following shows a quarry.



Fig. 1.3.9 Quarry

Mountaintop Removal Mining

This is the removing of overburden on a mountain-top to an adjacent valley. The following shows a mountaintop removal mining.



Fig. 1.3.10 Mountain top removal mining

Placer Mining

This is mining of river deposits for minerals. The following shows placer mining:



Fig. 1.3.11 Placer mining

Dredging

This is extracting minerals such as gold from sand, gravel, dirt using water and machines. The following shows dredging:



Fig. 1.3.12 Dredging mining

Hydraulic Mining

This is mining with high-pressure jets of water to remove rocks or sediment to mine minerals. The following shows hydraulic mining:



Fig. 1.3.13 Hydraulic mining

1.3.2.2: Under Ground Mining

Explain



This is mining for rocks under the ground. Underground mining can be of these types:

Sub-Surface mining

Here, mining is conducted underground. The following shows sub-surface mining:



Fig. 1.3.14 Sub surface mining

Drift mining

Here, mining is conducted horizontally underground. The following shows drift mining.



Fig. 1.3.15 Drift mining

Shaft mining

Here, mining conducted vertically underground. The following picture shows shaft mining.

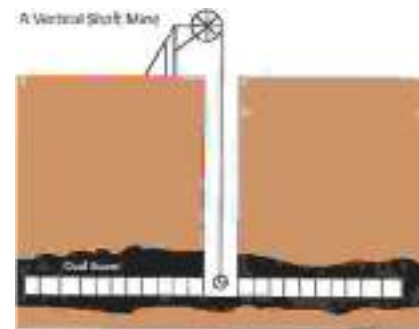

Fig. 1.3.16 Shaft mining

Slope mining

This is when shaft mining is done in a sloping way. The following picture shows slope mining.



Fig. 1.3.17 Slope mining

Room and pillar

In this mining system, the mined material is extracted across a horizontal plane, creating horizontal sets of rooms supported by pillars. The following picture shows room and pillar mining.



Fig. 1.3.18 Room and pillar mining

Longwall mining

In this form of mining, a long wall of coal is mined in a single slice. The following Picture shows longwall mining.



Fig. 1.3.19 Longwall mining

1.3.3: Phases in Mining

Elaborate

A mining project is done in multiple phases, from locating an area with deposits that can be mined, to closing a mining area. The following shows the various phases in mining:

Exploration

- Determining volume of deposit
- Surveys
- Field studies
- Drilling test Boreholes
- Exploratory excavations

Development

- Construction of access road
- Site preparation and cleaning

Active Cleaning

- Open-pit mining
- Placer Mining
- Underground Mining
- Reworking of inactive or abandoned Mines

Disposal of Overburden and Waste Rock

- Removal of cover soil or rock for access to ores or deposits

Ore Extraction

- Use of Machinery
- Transportation of Ore

Beneficiation

- Grinding the ore and separating relevant metal from the other Material
- Milling Techniques
- Chemical Technique

Tailing Disposal

- Disposal of Waste or tailings
- Tailings pond
- Dry Tailing disposal
- Sub-marine trailing disposal

Site Reclamation

- Closing of mining facilities
- Restoration of pre-mining conditions

Fig. 1.3.20 Key phases in mining

1.3.4: Activities in Surface and Under ground Mining

Explain

The following are the steps of mining operations in surface mining and underground mining:

Surface mining-

- 1- Site preparation
- 2- Mine Development
- 3- Ore Breakage / Overburden Removal
- 4- Drilling
- 5- Blasting
- 6- Excavating / Loading
- 7- Haulage
- 8- Beneficiation
- 9- Further Processing

Underground Mining

- 1- Site preparation
- 2- Mine Development
- 3- Room Pillar / Longwall technique for ore extraction
- 4- Ore Breakage (in Room Pillar) / Continue mining (Longwall)
- 5- Drilling
- 6- Blasting
- 7- Loading
- 8- Haulage
- 9- Beneficiation
- 10- Further Processing

1.3.5: Key Mining Terms and Definitions

Explain



- **Abandoned mine:** A mining area that is sealed and deserted and where mining activities no longer take place
- **Air blast:** A strong rush of air in a mine, caused by an explosion. Can contain hazardous gases
- **Air shaft:** A vertical opening into a mine to let in air for ventilation
- **Airway:** Any passage in a mine through which air current can pass
- **Bedrock:** The hard rock found under river beds or alluvium deposits
- **Bench:** A horizontal section of coal seam separated by slate or formed during the process of cutting coal
- **Black damp:** Carbon dioxide gas which can be hazardous
- **Blasting:** The technique of breaking rock by making a hole in it, filling it with explosives and firing.
- **Bore hole:** A hole of small diameter drilled to explore the layer of rocks ahead
- **Brusher:** A mine worker who repairs the roofs, sides or floor of a passage in a mine
- **Cautionary Zone:** A zone in which the mineral deposit lies within a specific distance from any source of danger such as water
- **Chamber:** An underground excavation area from which coal or other deposit is mined
- **Choke damp:** Carbon monoxide and carbon dioxide, which can be hazardous gases
- **Colliery:** A coal mine
- **Crushing:** Operation on rocks post blasting to break the rocks
- **Cut:** A hole or groove excavated on the deposit to prepare for blasting
- **Detonator:** A device for initiating the explosive for blasting
- **Drilling:** Making holes in rocks
- **Face:** The exposed vertical part of rock
- **Loading:** Putting blasted material on trucks or conveyor belts for transportation to processing centre
- **Overburden:** The material above the mineral deposit that needs to be removed to reach the deposit
- **Rock faced:** The natural face of the rock
- **Rubble:** Irregular shaped stones
- **Shake:** A fracture that occurs across the surface of a rock and breaks it across the plane of cleavage
- **Vent:** A hole or gap which indicates a source of weakness in the stine
- **Water blast:** Explosion of water under pressure, which happens when trapped air expands as water level is lowered

1.3.5.1: Common Tools for Mining

Demonstrate



- **Axe:** A tool with head of steel which is tapered on one or both ends, and fitted with a wooden handle
- **Boaster:** A broad-faced chisel for dressing a stone
- **Box trammel:** A tool for scribing parallel or circular lines
- **Bush hammer:** A tool with 4 to 10 thin blades of steel ground to an edge and bolted together on a handle
- **Chisel:** A steel tool with a plain shaft and a cutting edge
- **Circular saw:** A machine with a power-driven revolving steel disc for cutting stones
- **Dummy:** A mallet with a head made of lead or zinc to be used with wooden handled chisels
- **Fillet saw:** A small saw with adjustable handle

- **Pick:** A tool made of hard tempered steel tapered to a point at one or both ends, and fitted with a wooden handle
- **Splitter:** A hammer-headed tool 8 to 10 cm wide for cutting an edge
- **Tracer:** A large chisel for tracking a shallow groove along a series of holes for splitting a mass of rocks

Activity-1

- Conduct a 'Mining Method Presentation Activity'.
- Ask the students to make group of 5 students.
- Students have to Create Presentation on Mining Methods.
- One group of Students will have 60 minutes for creating presentation. 30 minutes for presentation.
- Appreciate identification skill of students and tell correct Mining Method, if any Mining Method is wrongly quoted.

Activity	Time	Resources
Mining Method Presentation Activity	4 Hours	Participant Handbook, Notebook, pen, Flipchart / Laptop,

Activity-2

- Conduct a 'Activities involved in Mining Activity'.
- Ask the students to make group of 5 students.
- Students have to Create Presentation on Activities Involved in Mining.
- One group of Students will have 60 minutes for creating presentation. 30 minutes for presentation.
- Appreciate identification skill of students and tell correct Mining Activities, if any Mining Activities are wrongly quoted.

Activity	Time	Resources
Activities involved in Mining Activity	2 Hours	Participant Handbook, Notebook, pen, Flipchart / Laptop,

UNIT 1.4: Stone Mining in India

Unit Objectives

At the end of this unit, students will be able to:

1. Discuss the location and types of marbles in India
2. Discuss various stages in marble mining
3. Discuss location and phases in granite mining in India

Resources to be Used

- Laptop
- Projector
- White Board
- Marker
- Duster
- Map of Rajasthan showing location of Marble Mining
- Marble Samples
- Field visit to Marble Mine
- Details and photos of Different machines used in Marble Mining

Do

- Greet the participants for the day.
- Give Summary of previous Session.
- Ask for any doubts in previous Session.
- Acknowledge for their doubt-raising, if any. Clear the doubts.
- Give details of today's session and what they are going to learn.
- Encourage them to share their thoughts and doubts now and during process of this course.

1.4.1: Marble Mining

Ask

- Places where marble is found?
- What are the types of Marble?

Explain



Marble is a 'minor mineral' as defined in the Mines and Minerals Act, 1957. It has multiple pleasant colours, smooth and uniform texture, moderate hardness and can be quarried into big blocks.

Technically, marble is formed from limestone which gets transformed due to heat and pressure, and recrystallises.

For miners and stonemasons, all rocks which contain calcium carbonate and capable of polish are termed as marbles. While marble is not a prime export such as other stone and granite, in India its demand and consumption is high. Marble is used as a building material and for sculptures.

The following figure shows a marble quarry and the use of marble.



Fig. 1.4.1. Use of Marble in building construction and a Marble Quarry site

1.4.1.1: Locations of Marble Mines

Elaborate



Marble is found in many states such as Rajasthan, Gujarat, Andhra Pradesh, Madhya Pradesh, Jammu & Kashmir, Maharashtra, Sikkim, Uttar Pradesh and West Bengal. Of these, the deposits in Rajasthan, Gujarat, Andhra Pradesh and Madhya Pradesh are economically important. Rajasthan has the best quality of marble, and the important marble occurrences are shown in the following.

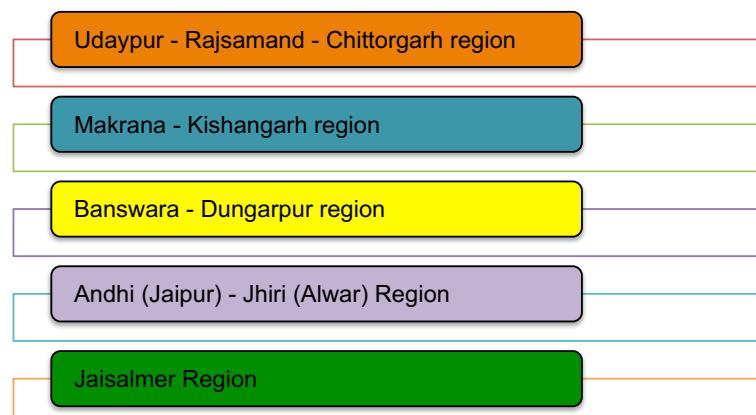

Fig. 1.4.2. Locations of marble sites in India

1.4.1.2: Types of Marble

Demonstrate

Following are key types of marbles:

- White marble
- Panther marble
- White veined marble
- Plain black marble
- Black zebra marble
- Green marble
- Pink Adanga marble
- Pink marble
- Grey marble
- Brown marble

Marble can also be classified by their chemical composition and origin. These include:

Calcite marble: Crystalline variety of limestone. Less than 5% magnesium carbonate. Varied from grey to white to any colour.

Dolomitic marble: Crystalline variety of limestone. Not less than 5% or more than 20% magnesium carbonate as dolomite molecules.

Dolomite marble: Crystalline dolomite with an excess of 20% magnesium carbonate as dolomite molecules. It has varied colours and textures. The lustre can be enhanced. Low cost and exotic colours. Found in Banswara in Rajasthan and Chhota Udaipur in Gujarat.

- **Siliceous Limestone:** Contains high silica, smooth and fine grained appearance. Difficult to cut and polish, available in various colours. Found in Babarmal and Alwar.
- **Limestone:** Various kinds are available. The Black marble of Bhainslana, Karta and Sirohi and golden-yellow marble of Jaisalmer are soft and requires frequent maintenance.
- **Serpentine or Green marble:** This has large amount of serpentine mineral and is in shades of green. Found in Gogunda, Rikhabdeo, Kesariyaji and Dungarput.
- **Onyx:** This is a dense crystalline form of lime carbonate deposited usually from cold water solutions. Usually transparent or translucent and used in decorative articles. Found in Kupwara district of Jammu and Kashmir.
- **Travertine marbles:** Variety of limestone regarded as a product of chemical precipitation

1.4.1.3: Mining and Processing

Say

In typical mining method, mined out minerals are obtained in small quantities.

On the other hand, in stone mining, including marble mining, large size intact blocks without any cracks or damages are extracted. Today, marble mining in India is done by manual, semi-mechanized or mechanized methods. In mechanized means, various kinds of equipment and machines are used. However, most mines use semi-mechanized methods.

1.4.1.4: Stages of Marble Mining

Explain

Explain various stages of marble mining which are:

- a. **Removal of Overburden:** This is the removal of material above the stone deposits. This is generally carried out with heavy earth moving machinery. Sometimes, this is done by drilling holes with **jackhammers** and slim drill machines. The holes are then charged with explosives and blasted in a controlled way, so that the overburden material is loosened. It is then removed with heavy earth-moving machinery such as excavators, tippers, and loaders.
- b. **Marking for Removal:** After the marble is exposed on removal of overburden, the area around is studied well. The joint and fracture pattern in the stone is minutely checked. Then a key block is marked for removal or for quarry front cut.
- c. **Cutting the Quarry front:** In manual operation, a line of shallow holes is made, and by driving in wedges with feathers by constant hammering, a fracture is developed along a block. The block is pulled out by chains r pulley system or is pushed by driving logs. Once the block is toppled, it is again cut and dressed for getting a parallel pipe shape.

In the semi-mechanised operation, jack hammers, slim drills, line drilling machines are used to create a block. The block is pulled out using cranes, winches, dozers, etc. Here the wastage is high and the size of blocks is small and defective.

To overcome these problems, the quarry front cut is made with slim drill machines, diamond wire saw, quarry master, diamond bell saw and chain saw machines.

1.4.1.5: Using Diamond Wire Saw for Cutting Quarry Load

Explain

Wire saws are large machines that use diamond-impregnated beads on a cable to cut through marble, granite and other similar rocks. Wire saw is also used for squaring of the cut slab into square shaped blocks before transporting to the production plant.

The drill machines are used to drill holes, through which the diamond wire saw is passed. The block is cut by continuous motion of the diamond wire saw. Once the block is cut, it is toppled with hydrobags, pneumatic pillows, air jacks, etc. In this method, exact sized blocks can be cut with minimum wastage.

The lifting and loading of blocks are done by Derrick cranes and various kinds of loaders. The following figure shows a loader:



Fig. 1.4.4. A Loader

1.4.1.6: Processing of Marbles

Explain

Processing is done in two stages.

- **Stage 1:** Here the blocks are cut into 2 to 3 cm slabs using gang saws, wire saws and circular saws. In marble tiled plants, the thickness of tiles can be 10 or 12 mm. The following figure shows using cutting marble:



Fig. 1.4.5. Marble cutting

- **Stage 2:** Tiles are polished using various pneumatically operated or other polishing machines such as line polishers, trimmed and cut to size, buffed, chamfered with various machines before selling.

Elaborate

Rajasthan has the capacity to process 95% of marble in India. Many gang saws and automatic tiling machines are used here.

Craftsmen in India develop art from marble using manual means and simple tools. Stone fairs are regularly organized in Rajasthan to promote stone artifacts and provide encouragement to sculptors and craftsmen.

Markana Marble Mines

The Markana area in Rajasthan is famous for its pure white marble and is known as the 'Marble City' of India. It is believed that marble mining in Markana started more than 1000 years ago, and marble from here was used to build the Taj Mahal. There are approximately 817 licensed quarries in Markana, with more than 50,000 workers.

1.4.1.7: Indian Standard Recommended Practice for Quarrying Stone for Construction Purpose

Explain

The Indian Standard IS 8381: Recommended Practice for Quarrying Stones for Construction Purpose, 1977 lays out the following practices for quarrying and mining of marble.

1.4.1.7.1: Selection of Quarry Site

Explain



- Quarrying of marble is done by cutting of the blocks of as big size as possible and free from cracks or flaws.
- One has to be very cautious while marble quarrying to ensure the blocks are of good quality.
- The blocks are separated by joints. Wide spacing of the joints increases the value of the deposit because in that case the blocks of bigger size can be excavated which fetch high prices.
- Besides joints, there are major and minor cracks, more so near the surface which disappears at depths.
- Miners are required to look for such issues.

1.4.1.7.2: Determining Quarrying Method

Explain



- The quarrying method should be decided after studying the features of a particular deposit.
- Quarrying of the marble includes removal of the overburden, opening of free faces, demarcation of the marble block and excavation of the block.
- So far underground mining for marble is not adopted in our country.

1.4.1.7.3: Removal of Overburden

Explain



- First of all overburden is removed which can be done manually.
- Blasting may be resorted to where hard top layer occur.
- Drilling of the holes may be done either by manual labour or by compressed air drill.
- The waste rock may be transported to sufficient distance away where there may not be any mineral deposit underneath.

1.4.1.7.4: Opening Free Faces

Explain



- Removal of the overburden exposes joints and planes of weaknesses at the top of the deposit. These must be examined closely.
- Then one free face is opened along the strike of the deposit while another free face is excavated across the strike.
- The channels of the free faces are cut by blasting holes of about 2.5 cm diameter and about 0.5 to 0.7 m in depth.
- At a time, only limited number of holes are blasted so that no damage may be caused to the block.
- The drilling of the holes for excavation of channels may be carried out either manually or with compressed air drill.
- The width of these channels is approximately 0.6 to 0.8 m.
- The depth of the channels may be from 3 to 6 m depending upon the availability of natural joint in depth. The lengths of these channels are decided upon by the distance between the joints across as well as along the strike.
- These joints thus demarcate the block which is under extraction.

1.4.1.7.5: Loosening the Block

Explain



- After opening these free faces, a single hole of about 4 to 5 cm in diameter is drilled roughly at a point where the joint perpendicular to the strike channel meets the joint perpendicular to the channel across the strike.
- The depth of this hole is about 30 to 35 cm less than the depth of the channel, so that effect of blasting may not be passed on to the block underneath.
- The hole is under charged with gun powder and blasted which causes the loosening of the block.

1.4.1.7.6: Separation of Bottom

Explain



- The block at the bottom can be separated by drilling the holes along the line determined by the thickness of the block desired, putting in the wedges and then hammering them in succession.
 - A series of holes may be drilled with spacing of about 5 to 10 cm.
 - These holes may be drilled either manually or by compressed air drills.
 - After drilling holes, wedges of about 15 to 20 cm in length are driven in and hammered lightly first followed by hard hammering so as to cause the separation of block from the bottom.
- The following figure shows the location of holes for blasting in marble quarries.

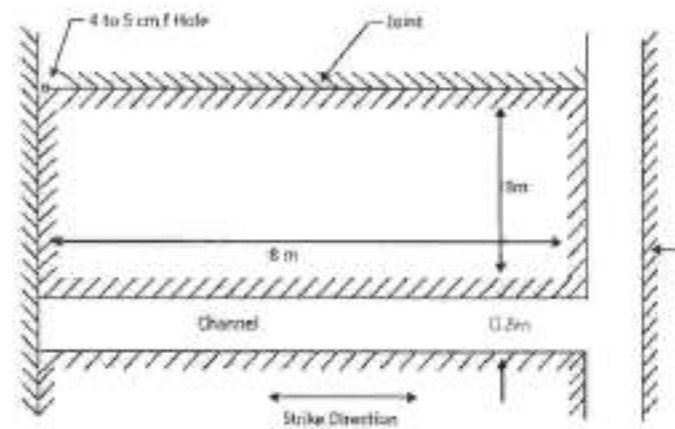

Fig. 1.4.6. Location of holes for blasting in a marble quarry

1.4.1.7.7: Wire Saw Method of Quarrying

Explain



Quarrying can be done with wire saw method which consists of the 1 or 3 strand ropes of 10 mm diameter which runs as a belt and cuts by grazing on the rock, when fed with sand and water.

1.4.1.7.8: Sub Division of Block

Explain



- The big block of the marble so cut is further subdivided to make smaller blocks.
- The procedure for extracting the smaller block also involves the drilling of the holes.
- The blocks are then dressed by chisels and hammers to make it perfectly rectangular.
- Then the blocks are lifted and loaded in the trucks and transported to the factory for further processing.

1.4.2: Granite Mining

Explain



Granite is a light-coloured stone containing other minerals, but commercially, all crystalline rocks with pleasing colours and strength to bear quarrying, cutting and polishing is referred to as granite.

Granite is more resistant to wear and tear, and so is in demand.

1.4.2.1: Location of Granite Mining in India

Demonstrate

India has a large deposit of granite, most of which is located in Rajasthan, Odisha and Karnataka, followed by Jharkhand, Gujarat, Andhra Pradesh and Madhya Pradesh. The following shows a granite mine:

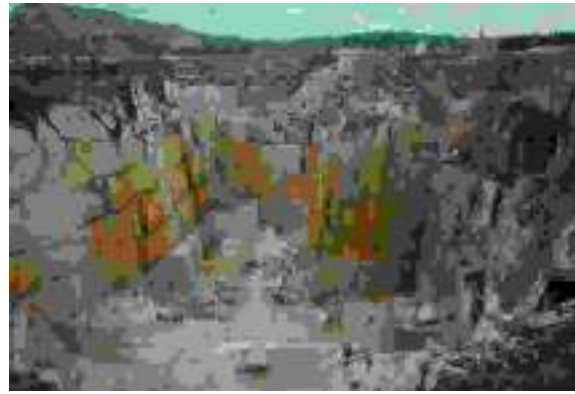

Fig. 1.4.7. A granite quarry

There are over 300 varieties of granite, out of which India supplies 200 varieties.

1.4.2.2: Stages in Granite Mining

Demonstrate

Mining of granite has two stages of operation.

Stage 1: The actual block splitting from either the sheet rock or boulder. This is done manually mostly, and in some cases by semi-mechanised methods. Some mines however use modern method of block splitting using flame-jet burner and wire saw for cutting.

Stage 2: Removal of overburden or weathered zone, opening of faces, lifting of cut blocks, transportation and other activities. This stage mostly uses mechanised methods. Heavy-duty derrick cranes can handle 50-tonne blocks from a depth of more than 60 m. Another modern method of recovery of dimensional blocks is water jet cutting technique. There is minimum cutting loss here and minimum damage to the adjacent block.

1.4.2.3: Processing Granite

Demonstrate

Granite has been traditionally hand polished or semi-hand worked in India. The processing today involves sawing or cutting raw blocks into tiles or slabs or required size and thickness and polishing. Edge cutting, milling, boring and contouring are other operations.

Granite is mostly used as a building material because of its strength, density, water absorption capability, colour and texture.

Environmental Effects of Stone Mining

Mining affects the environment adversely at times. Some effects of stone mining may be:

- Degradation and removal of top soil
- Disturbance of flora, fauna and water quality of the area
- Dumping of overburden or rejected blocks leading to hazards or increase in waste material in nearby areas
- Decrease in fertility of nearby land area
- Air, water and noise pollution

It is important that mining activities ensure these are minimized as much as possible.

Activity 

- Conduct a 'Standard Practice for Mining Presentation Activity'.
- Ask the students to make group of 5 students.
- Students have to Create Presentation on Standard Practice for Mining.
- One group of Students will have 60 minutes for creating presentation. 20 minutes for presentation.
- Appreciate identification skill of students and tell correct Steps for Mining Practice, if any Mining Step is wrongly quoted.

Activity	Time	Resources
Standard Practice for Mining Presentation Activity	2 Hours	Participant Handbook, Notebook, pen, Flipchart / Laptop,

UNIT 1.5: Mining Equipment

Unit Objectives

At the end of this unit, students will be able to:

1. List some key machines used in mines
2. Explain some basic electricity and electric motor concepts
3. List some major machinery handling hazards and safety precautions

Resources to be Used

- Laptop
- Projector
- White Board
- Marker
- Duster
- Details and Photos of machines used in Mining
- Field visit to Marble Mine

Do

- Greet the participants for the day.
- Give Summary of previous Session.
- Ask for any doubts in previous Session.
- Acknowledge for their doubt-raising, if any. Clear the doubts.
- Give details of today's session and what they are going to learn.
- Encourage them to share their thoughts and doubts now and during process of this course.

1.5.1: Machines used in Mining

Ask

- What are the main machines which are used in Mining?
- What is machine used to cut Marble from Quarry?

Say 

Surface mining requires the use of a number of machines and tools. Following are some of the most important tools used.

1.5.1.1: Diamond Wire Saw

Demonstrate 

A wire saw is a machine-powered saw that uses diamond embedded beads on a metal wire to cut through stones. It uses continuous scratching or rubbing to cut hard stones into large blocks. The wire passes around a fly wheel and is carried on pulleys to the part of the quarry where the cutting is to be done.



Fig. 1.5.1. A diamond wire saw

1.5.1.2: Air Compressor

Demonstrate 

In mines, air compressors are used as a source of electricity for powering drilling machines, conveyor belts or other machines. They are also used for supplying oxygen in underground mines. The following figure shows an air compressor.



Fig. 1.5.2. An Air Compressor

1.5.1.3: Jack Hammer

Demonstrate

This is an electrical tool that includes a hammer along with a chisel. With electricity the hammer strikes the chisel back and forth. Sometimes jackhammer also use compressed air supplied by an air compressor. The jackhammer is used for breaking rocks. The following figure shows a jackhammer.



Fig. 1.5.3. A Jackhammer

1.5.1.4: Hydraulic Drill

Demonstrate

This is a machine to drill holes on rocks. This machine is powered by hydraulic oil instead of compressed air or electric motor. The following figure shows a hydraulic drill.



Fig. 1.5.4. A Hydraulic Drill

1.5.1.5: Derrick Crane

Demonstrate

This is a rock lifting machine with a long tower. It is mostly fixed at a location. The tower helps in moving large pieces of rocks from one location to a nearby location.



Fig. 1.5.5. A Derrick Crane

1.5.1.6: Loader

Demonstrate



A loader is a heavy machine with a bucket like front. This is used to scoop heavy material and move it from one place to another.



Fig. 1.5.6. A Loader

1.5.1.7: Chisel

Demonstrate



This is a tool with a long blade which has a cutting edge. The blade is attached to a handle. This can be used to cut or shape rocks, or create fractures on the face of the rock.



Fig. 1.5.7. Chisel

1.5.1.8: Wedge

Demonstrate



This is a simple tool, triangular in shape with two inclined planes meeting on a sharp edge. Wedges can be used to push to pieces of rocks apart.



Fig. 1.5.8. Wedge

1.5.1.9: Hammer

Demonstrate

This is a machine to drill holes on rocks. This machine is powered by hydraulic oil instead of compressed air or electric motor. The following figure shows a hydraulic drill.



Fig. 1.5.9. A Hammer

1.5.1.10: Water Pump

Demonstrate

Most mines use a water pump to supply high pressure water for cutting and flushing rocks. Following figure shows a water pump:

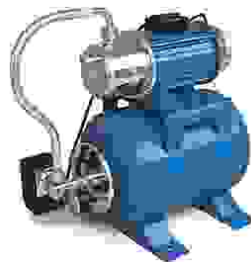

Fig. 1.5.10. A Water Pump

1.5.1.11: Excavator

Demonstrate

This is a big and heavy earth moving track mounting machine which includes under carriage, machine room, operator's cabin, boom & stick fitted with a bucket as front attachment. The complete machine with boom, stick and bucket can swing / rotate full circle on a platform. The platform sits on swing gear powered by swing motors. The propel mechanism for traveling is also powered by hydraulic motors, which drives under carriage.



Fig. 1.5.11. An Excavator

1.5.1.12: Hydraulic Jack

Demonstrate



A hydraulic jack is a machine which uses hydraulic power to lift heavy load or equipment by applying force. These can crush or break huge chunks of rocks.



Fig. 1.5.12. A Hydraulic Jack

1.5.1.13: Wagon Drills

Demonstrate



This is a machine that uses air pressure for rock drilling and blasting. The following figure shows a Wagon Drill



Fig. 1.5.13. A Wagon Drill

1.5.1.14: Diamond Belt Saw

Demonstrate



This is a huge cutting or sawing machine for making vertical or horizontal cuts. The tool has a special plastic belt with diamond segments.



Fig. 1.5.14. A Diamond Belt Saw

1.5.1.15: Chain Saw

Demonstrate

A machine with a toothed blade that can cut rocks vertically or horizontally. Chainsaws can be of various kinds. Mines use a type which has cutting edge of the blade embedded with diamond. The chain is lubricated with water. The following figure shows a diamond belt saw.



Fig. 1.5.15. A Chain Saw

1.5.1.16: Tipper

Demonstrate

A tipper is a truck used for transporting loose material. The following figure shows a tipper.



Fig. 1.5.16. A Tipper

1.5.2: Basic Electricity Concepts

Say

Most of the mining machinery today runs on electricity or motors. Understanding some basic electricity and motor concepts is crucial to understanding how the machines work or perform basic troubleshooting when required.

1.5.2.1: Common Electricity Terminology

Explain

In this section, some commonly used electricity concepts such as current, direct (DC) and alternating current (AC), voltage, resistance and electric circuit is explained.

1.5.2.1.1: Electric Current

Explain

Electric current is the flow of charged particles, just as water current is the flow of water in a particular direction. Charged electric particles in an electric current are electrons.

Electrons flow through a conducting medium such as metal or wire.

For electricity to flow, there must be a force to push them. This push or force is called voltage. The following figure shows the flow of electric current.

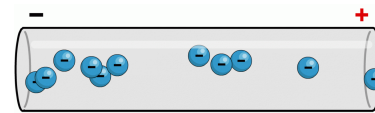

Fig. 1.5.17 Electric Current

1.5.2.1.2: Voltage

Explain

Voltage is the force needed to make electricity flow through a conductor. This is also known as electromotive force (emf). Voltage is measured in volts and is represented by symbol 'V' or 'E'. The bigger the voltage, the more current will flow. A battery can be used to provide voltage. A 12 volt battery will produce more current than a 1.5 volt battery. Voltage is measured by a voltmeter. The adjacent figure shows a voltmeter.



Fig. 1.5.18. A Voltmeter

The flowing electric current is measured with an ammeter. Electric current is measured in amperes or amps (A), and is denoted by symbol (I). Adjacent figure shows an Ammeter.



Fig. 1.5.19. An Ammeter

1.5.2.1.3: Power and Energy

Explain

Together voltage and current provide power. The more the voltage and the current, the more power it will provide. Electric power is measured in watts. Power is how much energy a machine is using per second. To find the total energy an electric machine uses, we use the formula:

$$\text{Energy} = \text{Power} \times \text{total number of seconds the machine is used for}$$

Electric Energy is measured in kilowatt per hour (kWh).

1.5.2.1.4: Electric Circuit

Explain

To create an electric current to flow in a conductor, we need a circuit. A circuit is a closed path or loop within which the electric current flows. A circuit can be made using a voltage source (such as a battery), conductors (such as wire). We can add an electrical load, which is the section that would consume the energy (such as a bulb, a machine or appliance). We can also add switches that will help us control the flow of electrical current. See in Fig. 1.5.20.



Fig. 1.5.20. A Complete Circuit

1.5.2.1.5: Resistance

Explain

Most materials have an in-built property to oppose the flow of electricity. This is called resistance. This is represented by 'R'. It is measured in ohms, with an instrument called ohm meter. The following figure shows an ohm meter.

As mentioned, flow of electric current is dependent on voltage.

Voltage can be calculated as:

$$\text{Voltage (V)} = \text{Electric Current (I)} \times \text{Resistance (R)}$$

In other words,

$$I = V/R$$

From this we can say that:

- 1- More the voltage, more the electric current
- 2- More the resistance, less the electric current



Fig. 1.5.21. An Ohm Meter

1.5.2.1.6: Alternating and Direct Current

Explain

Electricity can flow in two ways.

- **Direct Current:** When electricity always flows in the same direction, it is called direct current (DC). Some machines and motors use DC current. Batteries create a DC current as electrons flow from the 'negative' end of the battery to 'positive end' as shown in the figure below:



Fig. 1.5.22 Electric Current

- **Alternating Current:** In this type, the electrons can constantly reverse their direction many times in a second. Though it may seem impossible, but this flow is so quick that the machines or appliances can use this well to work.

The following figure shows direct current and alternating current.

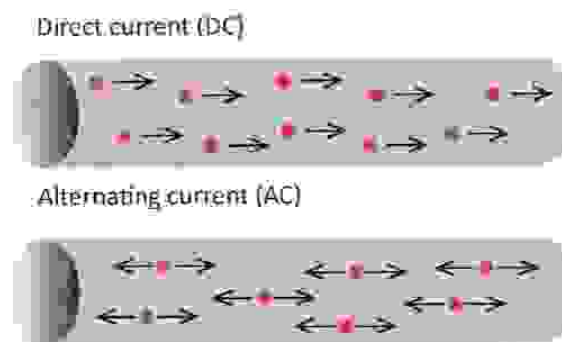

Fig. 1.5.23. DC and AC current

1.5.2.1.7: Electromagnetism

Explain

You may have seen a magnet. A magnet has two ends called North Pole and South Pole. The north pole of a magnet attracts the south pole of a second magnet. On the other hand, poles of similar kind repel each other. A magnet creates an invisible area of magnetism called a magnetic field. You can create a temporary magnet by passing electricity through a coil wrapped around an iron object such as a nail. These temporary magnets are called electromagnets:

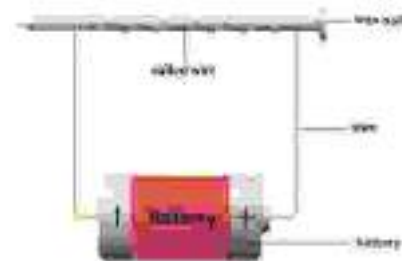

Fig. 1.5.24. A Simple Electromagnet

When an electric current flows in a wire, it generates a magnetic field around it. Similarly you can use a magnet to generate electricity. This is called electromagnetism. An electromagnet is a magnet that can be switched on or off using electricity.

1.5.2.1.8: Electric Motor

Demonstrate



An electric motor is a machine that turns electricity into mechanical energy to make the motor spin. It uses electromagnetism to work. This can in turn make a machine work.

A DC motor is one that converts DC electrical power to mechanical power. It's speed can easily be controlled by varying the supply of voltage or changing the strength of current. However machines with DC motors are likely to lead to fire, electrical shock in inflammable circumstances, and need more maintenance.

An AC motor is driven by alternating current. AC motors typically require more batteries, and machines with AC motors are more expensive. However they are more reliable and can run for longer time.



Fig. 1.5.25. A Simple Electric Motor

1.5.2.2: Handling Machines

Elaborate



Machines are an important part of work in mines. However, it is also important to be careful and alert while using them. Carelessness while using machines or malfunctioning of machines can lead to several kinds of hazards. Some of these hazards are listed below figure.

Electrical Hazards

- Hazard when a machine is malfunctioning and gives electric shock
- Hazard when a worker touches a bare electric circuit or socket by mistake

Trapping Hazards

- Body Part drawn between two counter rotation parts
- Cloths, hair, jewellery, cleaning rages and other items entangles in machine parts

Impact Hazards

- Being struck by moving parts of a machine
- Being caught between two moving or one moving and one fixed part of a machine

Cutting Hazards

- Hazards during using cutting tools such as saws, boring or drilling machines, water jets or other sharp material
- Injuries due to flying chips or scrap material striking head, eyes or other body part

Heat or cold Hazard

- Contact with extreme heat or cold part of machine
- Contact with a machine part which have been in motion or running for a long time

Noise Hazards

- Hazard when a work location is typically noise and the worker does not have enough safety equipment
- Hazard with malfunctioning machines which suddenly makes noise to which the worker is exposed to

Location of Machine Hazards

- Hazard while large machines are being moved from one location to other
- Hazard when a huge machine is not placed on stable or level ground

Fig. 1.5.26. Hazards due to machines and equipment

1.5.2.3: Safe Handling of Machines

Elaborate

It is important to be careful while handling machines. following are some steps that should be taken by organisations to minimize machine and equipment hazard risks.

- Only trained and qualified workers take up the tasks of operating , clearing blockage, clearing, adjusting, setting uu, maintaining, repairing or working of a machine.
- The heavy equipment or machines area is properly demarcated and all authorised worker are trained on usage and safety measures of handling machines.
- Machines are well tested and installed correctly. There should be no electrical leakage, undesirable water logging or open wires around the machine.

- It is ensured that heavy machines are set up stably and firmly on ground before usage.
- Machines are transported from one place to another place carefully.
- Proper safety equipment and clothing is used while operating a machine or working in a hazardous work location such as a mine.
- Malfunctioning machines are not used and any malfunction is reported and repaired immediately.
- In workplaces with loud noise, worker should be trained on communicating with hand gestures or signs, and the schedule for using explosives or dangerous machinery must be made known to all relevant people.
- Logs and records of usage of all machines must be maintained regularly.

Activity

- Conduct a 'Mining Equipment Details Presentation Activity'.
- Ask the students to make group of 5 students.
- Students have to Create Presentation on Equipment used in Mining.
- One group of Students will have 60 minutes for creating presentation. 30 minutes for presentation.
- Appreciate identification skill of students and tell correct Mining Equipment, if any Mining Equipment is wrongly quoted.

Activity	Time	Resources
Mining Equipment Details Presentation Activity	2 Hours	Participant Handbook, Notebook, pen, Flipchart / Laptop, Mining Equipment / Photos of Mining Equipment

Field Visit

- Field visit to mine site.

UNIT 1.6: Duties and Responsibilities of a Wire Saw Operator

Unit Objectives

At the end of this unit, students will be able to:

1. Understand the job responsibilities of a wire saw operator
2. Understand the key competencies required to be a wire saw operator

Resources to be Used

- Laptop
- Projector
- White Board
- Marker
- Duster
- Field visit to Marble Mine
- Career Map of Wire Saw Operator

Do

- Greet the participants for the day.
- Give Summary of previous Session.
- Ask for any doubts in previous Session.
- Acknowledge for their doubt-raising, if any. Clear the doubts.
- Give details of today's session and what they are going to learn.
- Encourage them to share their thoughts and doubts now and during process of this course.

1.6.1: Introduction to a Wire Saw Operator

Ask

- What are the roles of a Wire Saw Operator?
- What are the responsibilities of Wire Saw Operator?

Say

A Wire saw operator operates a Wire saw machine which is used to cut large blocks of stone out from the marble quarry.

Operating a Wire saw is a specialized task that can be safely performed only with adequate training and experience. Wire saw operators are also responsible to ensure basic upkeep of the machine and safety in operations.

The following figure shows the career map of a wire saw operator.

Explain

MD/Business Head					
Corporate Manager - Mining/Engineering/Resources					
Head Mining Projects/Departmental Heads					
Mining Engineer (OC/UG)					
Geotechnical Engineer (OC/UG)					
Surveyor	Mining Engineer				Mine Ventilation Supervisor
	Geotechnical Engineer				
	Mining Supervisor / Mining Mate				
Assitant Mine Surveyor	Rig Mounted Drill Operator	Blaster/Shot Firer, Explosive Van Operator	HMM Operators (Excavator, Loader, Dumper, Bulldozer and other vehicle driver, Grader, Bucket wheel Excavator, Surface minor, etc.)	SDL & LHD Operator, Track Layer Operator, Long Wall operator, Haulage Operator	Winding Engine Operator, Banks man, Roof/cable Bolter, Gas Detector, Ventilation Adequecy Checker, Strata Monitoring Operator, Road Header operator, Scale Operator
	Wire Saw Operator		Stacker and Reclaimer Operator, Mobile Conveyor Operator		
	Jumbo Operator				
	Jack Hammer Operator				
		Explosive Handler			Timberman
Unskilled Helper			Skilled Helper		

Fig. 1.6.1. Career map of a wire saw operator

Elaborate

Following are the key job responsibilities of a wire saw operator.

- Conduct pre-checks to ensure the wire saw is safe to use.
- Record details of daily checks.
- Adhere to the time limits and tasks given by the supervisor.
- Move the wire saw machine in required directions by trimming or towing
- Position and mount the wire saw machine
- Perform wire saw operations efficiently
- Be aware of the hazards and take necessary cautionary measures
- Prepare reports of problems or incidents
- Record and document tasks completed and other required paperwork within stipulated time
- Understand and comply with the health and safety measures required in open case mines

Explain

This job requires the operator to concentrate on the job at hand and complete it effectively and efficiently without any accidents. Following are some of the required competencies expected in the job role of wire saw operator:

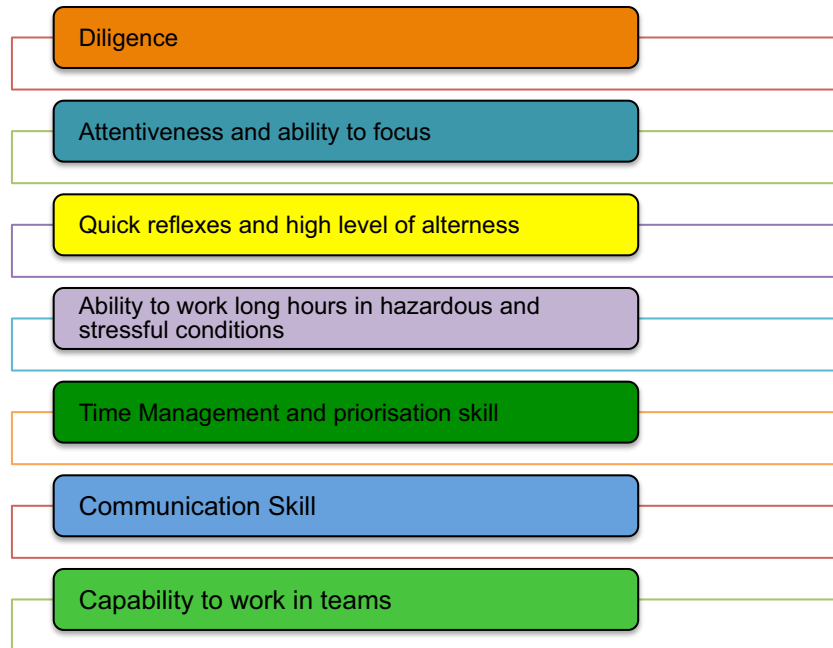

Fig. 1.6.2. Key competencies of a wire saw operator

Activity

- Conduct a 'Wire Saw Operator Roles Activity'.
- Ask the students to make group of 5 students.
- Students have to Create Presentation on Wire Saw Operator Roles.
- One group of Students will have 40 minutes for creating presentation. 20 minutes for presentation.
- Appreciate skill of students and tell correct Wire Saw Operator Roles, if any Role is wrongly quoted.

Activity	Time	Resources
Wire Saw Operator Roles Activity	2 Hours	Participant Handbook, Notebook, pen, Flipchart / Laptop,



Skil India
कौशल भारत-कुशल भारत



सत्यमेव जयते
GOVERNMENT OF INDIA
MINISTRY OF SKILL DEVELOPMENT
& ENTREPRENEURSHIP



N · S · D · C
National
Skill Development
Corporation

Transforming the skill landscape



2. Prepare the Wire Saw

Unit 2.1 - The wire saw machine and its parts

Unit 2.2 - Preparing the wire saw machine for operation

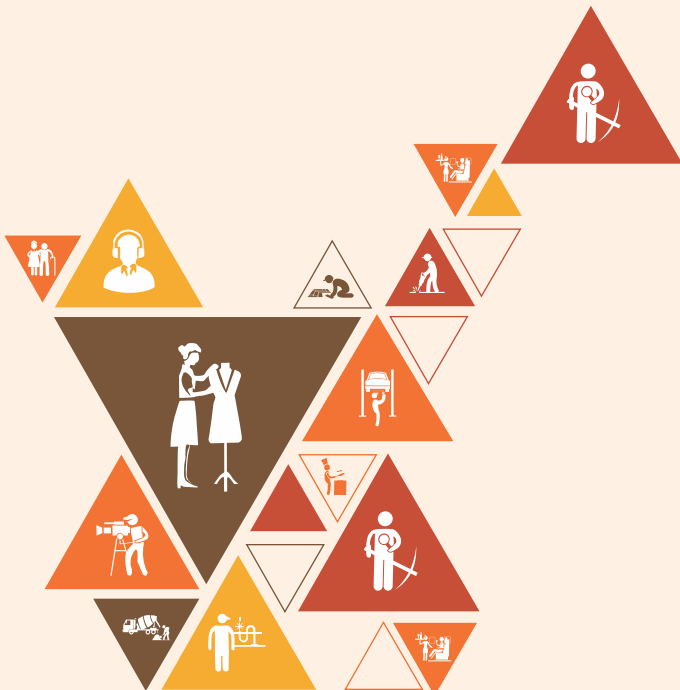

MIN/N0209

Key Learning Outcomes

At the end of this module, students will be able to:

1. Describe the various parts of a wire saw machine
2. Identify the broad steps to use a wire saw machine
3. Prepare the wire saw machine for operation
4. Perform regular inspections

UNIT 2.1: The Wire Saw Machine and Its Parts

Unit Objectives

At the end of this unit, students will be able to:

1. Describe a wire saw
2. Explain the functions of various parts of a wire saw machine
3. Identify the power supply to a machine
4. Identify the steps to use a wire saw machine
5. Explain the purpose and function of the diamond wire saw
6. List the various types of wire saws
7. Explain the various types of deposit areas

Resources to be Used

- Laptop
- Projector
- White Board
- Marker
- Duster
- Details and Photos of Wire Saw Machine Parts
- Wire Saw Machine

Do

- Greet the participants for the day.
- Give Summary of previous Session.
- Ask for any doubts in previous Session.
- Acknowledge for their doubt-raising, if any. Clear the doubts.
- Give details of today's session and what they are going to learn.
- Encourage them to share their thoughts and doubts now and during process of this course.

2.1.1: Description of Wire Saw Machine

Ask

- What are the main Parts of Wire Saw Machine?
- Whether machine is run on AC or DC?

Say 

A wire saw is a machine for cutting stones in marble mines. This is also used in granite and other natural stone mines. The following figure shows a wire saw machine at work:

Explain 

The machine has a fly wheel attached to a gear box via a 1400 rpm electric motor. The main motor on the machine rotates the fly wheel. The fly wheel has a diamond segmented wire rotating on it. This wire is passed through holes drilled in the rock segment which needs to be cut. The wire helps in making a cut in the direction required.



Fig. 2.1.1. Wire Saw machine in Action

The machine is placed on a railing (travelling track). The track moves in the direction opposite to the direction of cutting with the help of a DC motor. This helps create a tension on the wire to slice off the stone. Following are the figures showing broadly how a wire saw works:

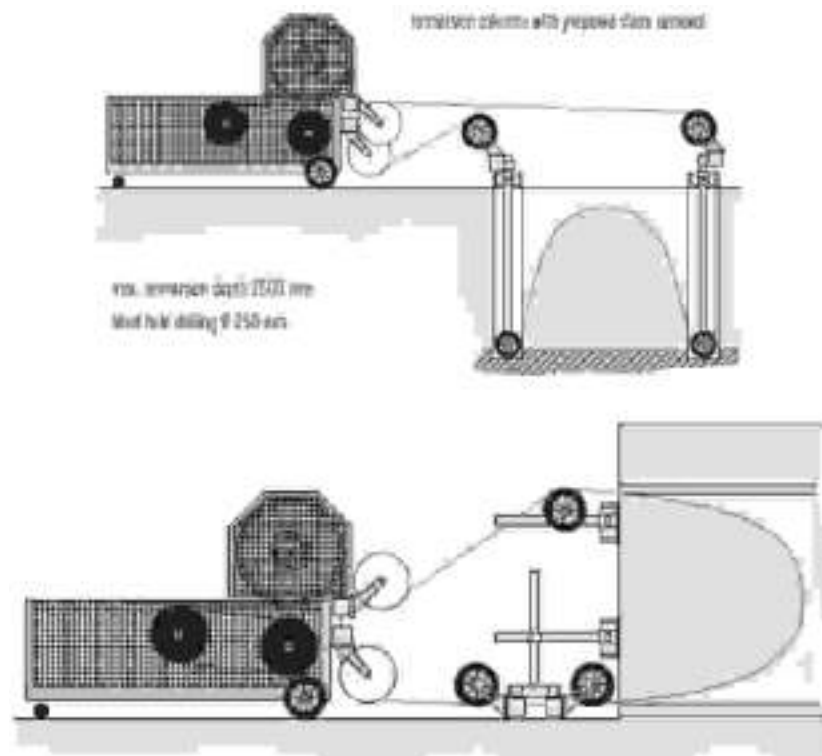

Fig. 2.1.2. Working of a Wire Saw Machine

2.1.2: Key Parts of Wire Saw Machine

Demonstrate

The key parts of a wire saw machine are as follows:

1. **Main motor:** Rotates the fly wheel attached to the wire saw.
2. **DC motor:** Helps in movement of Wire Saw on the railing (travelling track).
3. **Fly wheel (main pulley):** On which the diamond segmented wire rotates.
4. **Water pump:** Is used to cool the diamond segmented wire with water and to clean the cut.
5. **Railing (travelling track):** Track on which the wire saw moves.
6. **Guide pulley:** Helps in keeping tension in diamond segmented wire and giving it direction.
7. **Safety guard:** Safety equipment installed on the wire saw.
8. **Electric control panel:** For controlling the control the main motor, DC motor and water pump, and attached to the machine with a cable.

The following figure shows the main motor, flywheel, gear box, guide pulley, electric control panel and railing (travelling track) in the wire saw machine.



Fig. 2.1.3. Parts of a Wire saw machine

The Following figure shows the railing track of a wire saw machine:



Fig. 2.1.4. The railing track for movement of a wire saw machine

Explain typical specifications of a 60 HP wire saw machine.

Specification

- 60 HP A.C. Electric main motor
- 1 HP DC motor coupled with gearbox for traveling movement
- Electrical control panel with 10 m control cable
- Traveling track
- 800 mm main pulley giving wire speed of 24m/sec.
- 2 pieces guide pulley
- Pulley guard and spline shaft cover guard
- Wire cutter
- Crimping tool
- Stand for guide pulley

Dimensions

- Height: 1200 mm
- Length: 2700 mm
- Width: 1300 mm

Total Weight

- 1900 kg (Approx)
- The diameter of the fly wheel can increase or decrease according to the HP of the electric motor attached to the Wire Saw.
- The diameter of the fly wheel is attached to a 60 HP Wire Saw is 800 millimeters.

2.1.3: Power Supply to the Machine

Explain



1. The electric control panel of a wire saw machine is attached to an electric supply line. It is also connected to the machine via a cable. This panel has switches to control the main motor for the machine, the DC motor and the water pump.
2. With a change in switch in the control panel, the fly wheel can rotate in either clockwise or anti clockwise direction.
3. Similarly, with the help of taper turning ring attached to the Wire Saw, the fly wheel can rotate in the vertical or horizontal plane.
4. The fly wheel holds the diamond wire, which can be used in a controlled manner to cut through stones.
5. A 1 HP DC motor is attached to the wire saw machine. This motor gets DC power via a rectifier (a device which converts AC current to DC current).
6. The wire saw machine moves on the railing (travelling track) which is powered by the DC motor. Due to this, the diamond segmented wire stays in tension.

The following figure shows the various switches on the electric control panel.

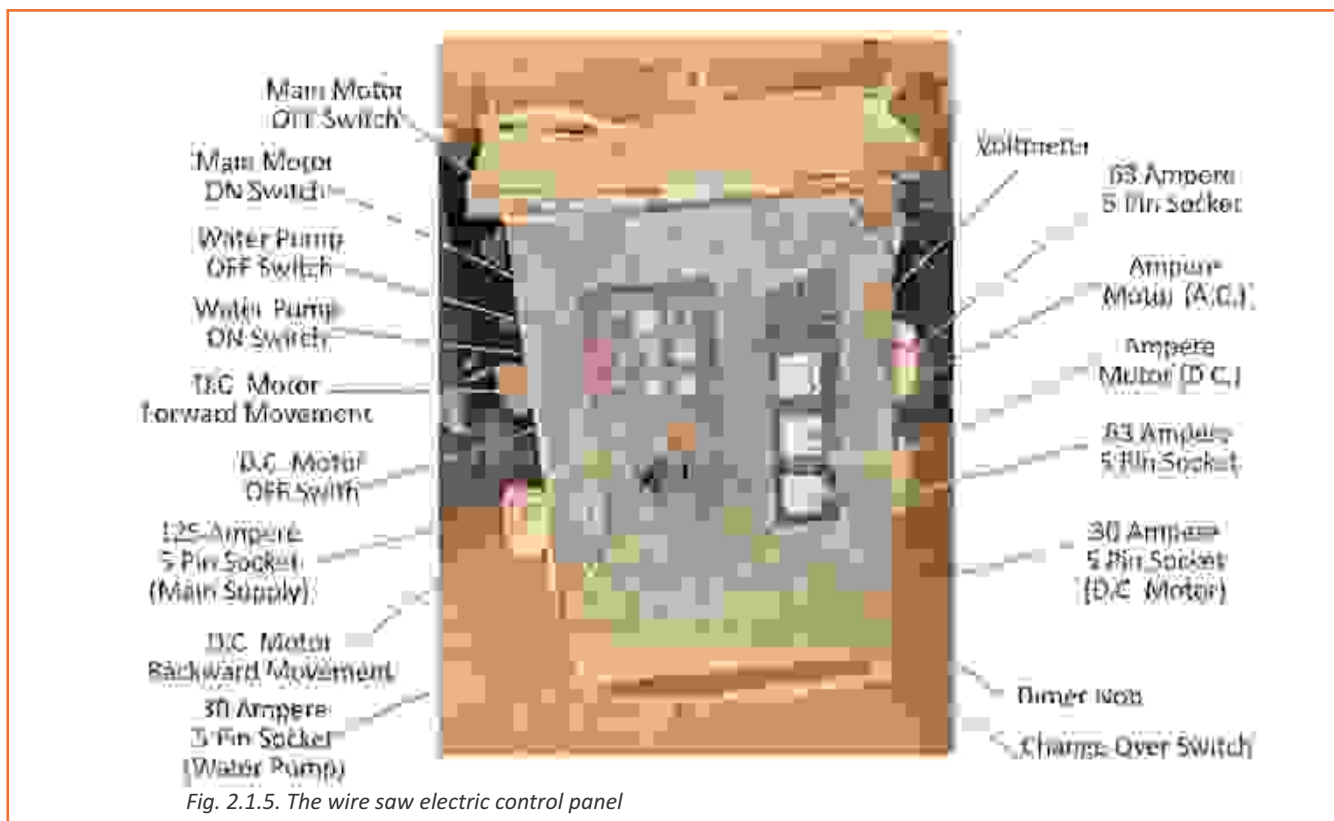

2.1.4: Steps to use Wire Saw Machine

Explain

Steps to Use the Wire Saw Machine

As mentioned, the fly wheel has a diamond segmented wire, which rotates and cuts the stones. The following figure shows a diamond wire placed over the flying wheel.



Fig. 2.1.6. The fly wheel and puller

Step 1: The diamond segmented wire is put in the vertical and horizontal hole made in the marble rock. The following figure shows this step.



Fig. 2.1.7. The diamond wire

Step 2: The wire goes over the guide pulley and is mounted on the fly wheel of the wire saw. This wire constantly rotates on the fly wheel and cuts the stones.

Step 3: Along with this, the Wire Saw moves in the direction opposite to the direction of the cutting with the help of the railing (travelling track).

Due to this, the diamond segmented wire remains in tension. This tension force is around 120-300 kg force, and this can be adjusted to get the optimum cutting rate considering the condition of the rock. This is necessary for cutting.

This is explained with the help of the following figure.

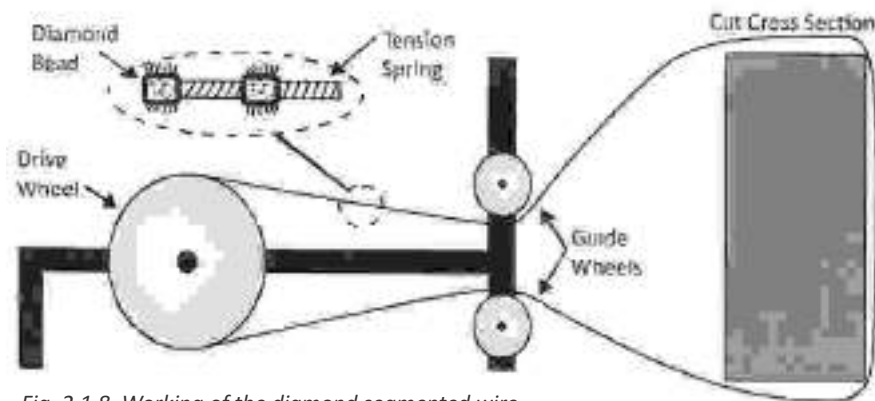

Fig. 2.1.8. Working of the diamond segmented wire

Step 4: Once the movement on the railing is complete, the Wire Saw is brought back to its initial position.

Step 5: The diamond segmented wire is cut, made smaller, and rejoined, and then mounted on the fly wheel again.

The marble block is cut due to the tension in the diamond segmented wire and its constant rotation and spinning.

Step 6: Watering facility is provided to cool the wire and to clean the cut. This needs about 25 to 40 liters of water per minute. This concept is also used during other applications of the wire saw such block cutting, sizing and dressing.

The following figure shows a diamond segmented wire.

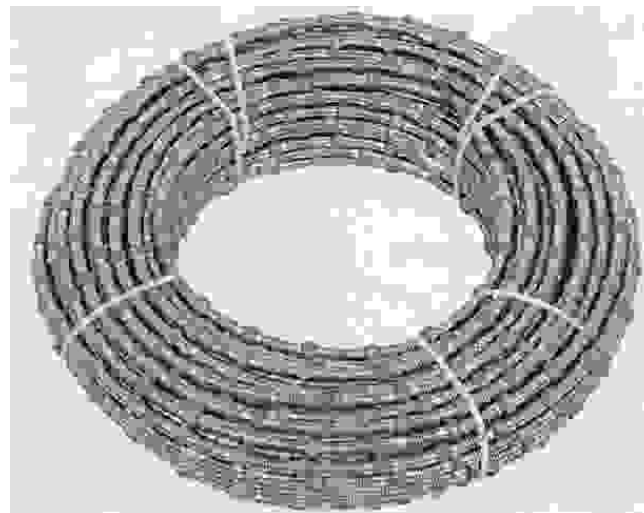

Fig. 2.1.9. The diamond chain

2.1.5: The Diamond Chain

Demonstrate

The diamond segmented wire is the most important part of the Wire Saw operation for cutting marble and other natural stones.

The main ingredients for making the chain of the diamond segmented wire are mark big spring, segment washer, lock and small spring as shown in the following figure:



Fig. 2.1.10. Parts of a diamond chain

As you can see, 3-4 diamond segments are put in between 2 locks. There is a washer before and after each segment, and there is a big spring between two washers. After every 2-3 segments, there is a lock and small spring as shown in the figure.

The figure below shows a vertical cut face on a block using a diamond wire.

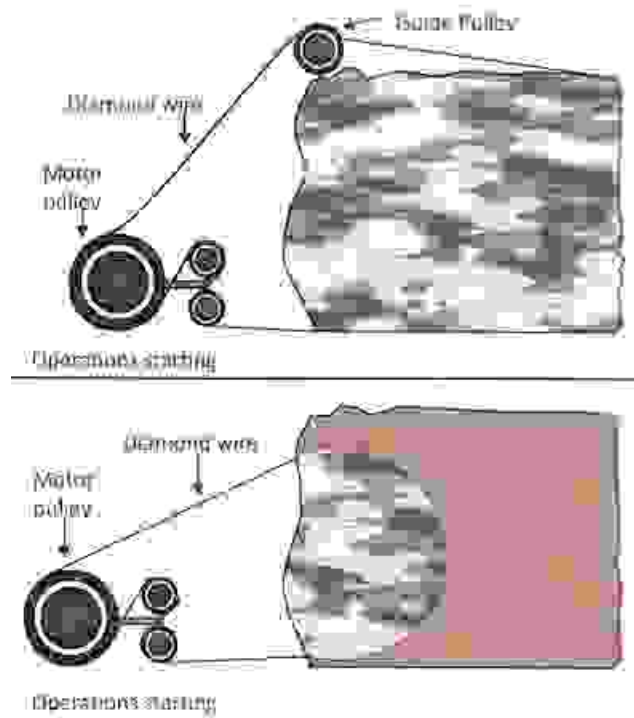

Fig. 2.1.11. Working of a diamond wire

2.1.5.1: The Base Wire

Demonstrate

The wire inside the chain (or the base wire) is of many types and many sizes. Its size and type depends on the way it works and the diameter inside the diamond segment. Normally, ordinary base wire is used. Even though the cost of the laminated base wire is more, its life is also very long.

The diameter of the base wire is 4.9 mm and ordinarily it depends on the inner diameter of the diamond segment.

- A base wire should have the following features:
-
- A base wire should be very flexible.
-
- The width of the base wire should be constant.
-
- The base wire should not be made of tough material.
-
- If the base wire is bent using hands, and if it comes back to its original position, then the wire is good. If the wire does not come back to its original position, or there is a knot then that wire cannot be used.

2.1.5.2: The Diamond Segment

Demonstrate

The diamond segment is the most important part of the wire saw machine, and comes in various types. However, two types of diamond segments are used most commonly.

- Sintered diamond segment
- Electroplated diamond segment

2.1.5.2.1: Sintered Diamond Segment

Demonstrate

Sintered diamond segment has a good life with the sawing speed almost constant throughout their lifetime. They can cut all types of rocks. They are also highly priced. Normally, sintered diamond segments are used in marble/other natural stone mines. The diameter of the diamond segment is 11 mm and the length is 11 mm.

2.1.5.2.2: Electroplated Diamond Segment

Demonstrate



The speed of the electroplated diamond segment is more. Its beads are made from an annular steel support onto which the diamond grains are electrolytically deposited. They are also very sharp. This it is also suitable for small cuts and cutting blocks. That is why both segments are important in the marble/other natural stone mines.

Following pictures show a sintered and electroplated diamond segments.

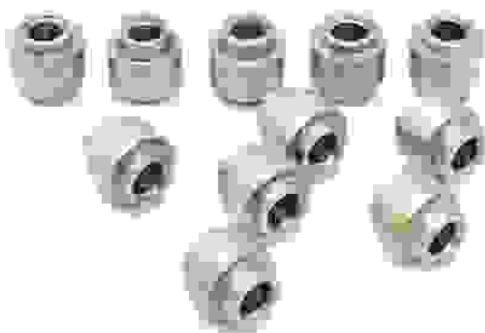

Fig. 2.1.12. Sintered diamond segment



Fig. 2.1.13. Electroplated diamond segments

2.1.5.3: Other Accessories

Demonstrate



Other than base wire and diamond segment, the following accessories are used to make diamond segmented wire.

1. Big spring – material steel (carbon 0.40%)

- Length – 28.0 mm +/- 0.20 mm
- Inner diameter 5.10 mm + 0.10 mm
- The diameter of the wire used to make the spring 1.20 mm
- Both ends of this spring should be flat grinded.

2. Small spring – material steel (carbon 0.40%)

- Length – 12.00 mm ±0.20 mm
- Inner diameter 5.10 mm + 0.1 mm
- Outer diameter 8.00 mm + 0.05 mm

3. Lock – material steel (carbon 0.13%)

- Length – 6.00 mm ±0.20 mm
- Inner diameter 5.10 mm + 0.1 mm
- Outer diameter 8.00 mm + 0.05 mm

4. Washer – material steel (carbon 0.20%)

- Width 3.00 mm ±0.10 mm
- Inner diameter 5.10 mm + 0.10 mm
- Outer diameter 8.00 mm + 0.05 mm

5. Sleeve (iron jointer)

- Length 21.00 mm \pm 0.10 mm
- Inner diameter 5.10 mm + 0.3 mm
- Outer diameter 9.00 mm + 0.05 mm

The big spring is used to give tension to the segment (bead) in the diamond segmented wire. It is important that both ends of the big spring are level.

We can check this by keeping the spring on level ground.

- If the spring stands straight it is level.
- If the end of the spring is not level, then it directly affects the diamond segment.

If the spring is not level, then it makes the washer attached to it crooked and the segment becomes crooked and does not move in a straight line. Thus it gets worn out in a crooked manner. Sometimes if the spring is not level, its end pierces the washer and the washer jams the segment due to which the segment is negatively affected.

Before installing the spring, we should have information about the cutting place. If it is rock hard, then more tension should be kept. If it is soft, then less tension should be kept.

2.1.5.4: Locks

Demonstrate



A lock is used after every three or four segments in the diamond segmented wire chain so that in case the chain breaks then all segments do not break, and there is less chance of an accident.

Two types of locks are available in the market:

- Copper lock
- MS lock

Mostly MS locks are used. To test its quality, if it is struck with a hammer, then it should flatten but not crack.

2.1.5.5: Small Spring

Demonstrate



It is used to maintain the distance between two segments and also to give tension to the segment near the lock.

The quality of the small spring can be tested just like the big spring.

If we put segments on both sides of the lock when making the diamond segmented wire chain, then only the segment which has the spring behind it gets tension. But when the chain moves, the segment in front of the lock does not get tension, so there is a chance of segment becoming spoilt.

2.1.5.6: Washers

Demonstrate

In order to prevent the segment from being worn, washers are installed on both its sides so that the life of the segment increases. Thus, it is necessary to test the quality of the washer. If the washer is not made of the correct material or of the correct size, then it will directly affect the segment.

During testing if the washer breaks into four pieces with one strike of the hammer, then the quality is acceptable, but if the washer flattens then the washer is not correct. The segment can be negatively affected because of this. This kind of washer makes a place in the sleeve of the segment and sometimes because of the sleeve inside the segment being cut, the coating on the segment is removed.

2.1.5.7: Sleeve Joiner

Demonstrate

The sleeve is used to connect the two ends of the diamond segmented wire chain. There are two types of sleeves available in the market:

- Copper sleeve
- MS sleeve

The copper sleeve has more capacity than the MS sleeve, but where the iron content in the rock is more the MS sleeve is used.

In order to test the quality of the sleeve if the sleeve completely flattens when struck with a hammer then the quality is ok, if it cracks then the quality is not good.

The figure below shows the various types of connections.



Fig. 2.1.14. Parts of a diamond segmented wire

2.1.5.8: Making Diamond Segment for Wire Saw

Demonstrate



Following things have to be taken care of when making diamond segmented wire saw chain:

- Quality of the segment used for making the chain
- The hardness of the rock and presence of elements like quartz, mica in it
- Speed of production

Following are some key considerations:

- While making the chain, the arrangement of all the materials being used should be uniform throughout the chain, and they should be thoroughly inspected.
- The condition of the rock should be taken into consideration when we apply tension to the chain.
- If the chain is being made for the first time, then care should be taken that the tension is a little less because the diamond on the segment has not opened yet. When making the chain for the second time, the tension can be changed. Similarly, after the chain is used many times, then the size of the materials used in making the chains should be changed.

The diamond chain is made after taking into consideration the above issues and to ensure that maximum speed and the life of the segment is increased.

The figure below shows various types of diamond wires.



Fig. 2.1.15. Types of diamond wire

The making of diamond wire is shown in the following figure:



Fig. 2.1.16. Making diamond chain

2.1.6: Types of Wire Saw

Explain



The Wire saws can be dependent on motor speed, on type of traveling rail motor and on the composition of marble.

2.1.6.1: Depending on Motor Speed

Elaborate



Wire saws can be classified into the following types based on the speed of the main motor:

1. Fixed Speed Wire Saw
2. Variable Speed Wire Saw

Nowadays, the fixed speed wire saw is used in most places. These can be classified into 20, 40, 60 HP wire saws according to their HP. These are used in various kinds of mines according to their requirements, for example:

- The 20 HP Wire Saw is used mostly for dressing and sizing of blocks.
- The 40 and 60 HP Wire Saw is used for primary cutting in order to demolish mega blocks.
- 25, 30, 50 HP Wire Saws are also available in the market.

2.1.6.2: Depending on Type of Travelling Rail Motor

Elaborate



Wire saws can also be classified into on the basis of the travelling rail motor.

1. Wire Saw with DC motor
2. Wire Saw with AC drive

The following figure shows a 60 HP wire saw with DC motor and electric panel:

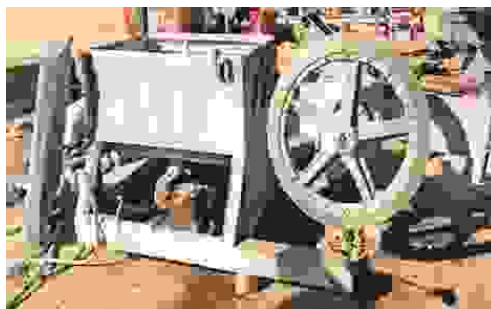

Fig. 2.1.17. A wire saw with DC motor

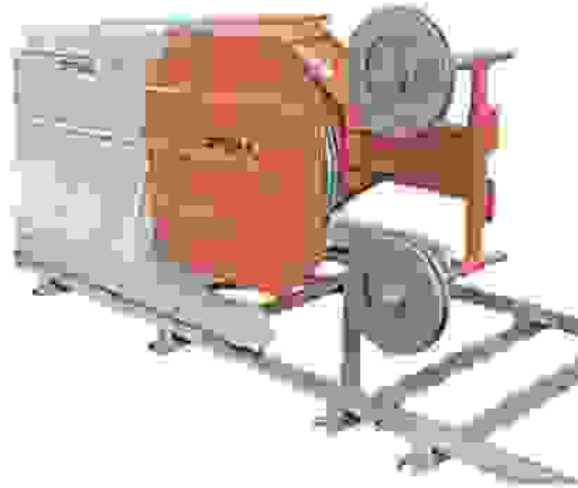

Fig. 2.1.18. A wire saw with AC motor

In this case, if the diamond wire becomes loose or tight, then the tension is kept constant automatically with the help of current transformer and a programmable logic controller (PLC). This means that whenever the diamond segmented wire is loose or tight; its signal is sensed by the current transformer and sent to the PLC. The PLC commands the drive if needed so that the speed of the AC motor will be increased or decreased and the tension of the diamond segmented wire can be kept constant.

The following figure shows the AC drive circuit:

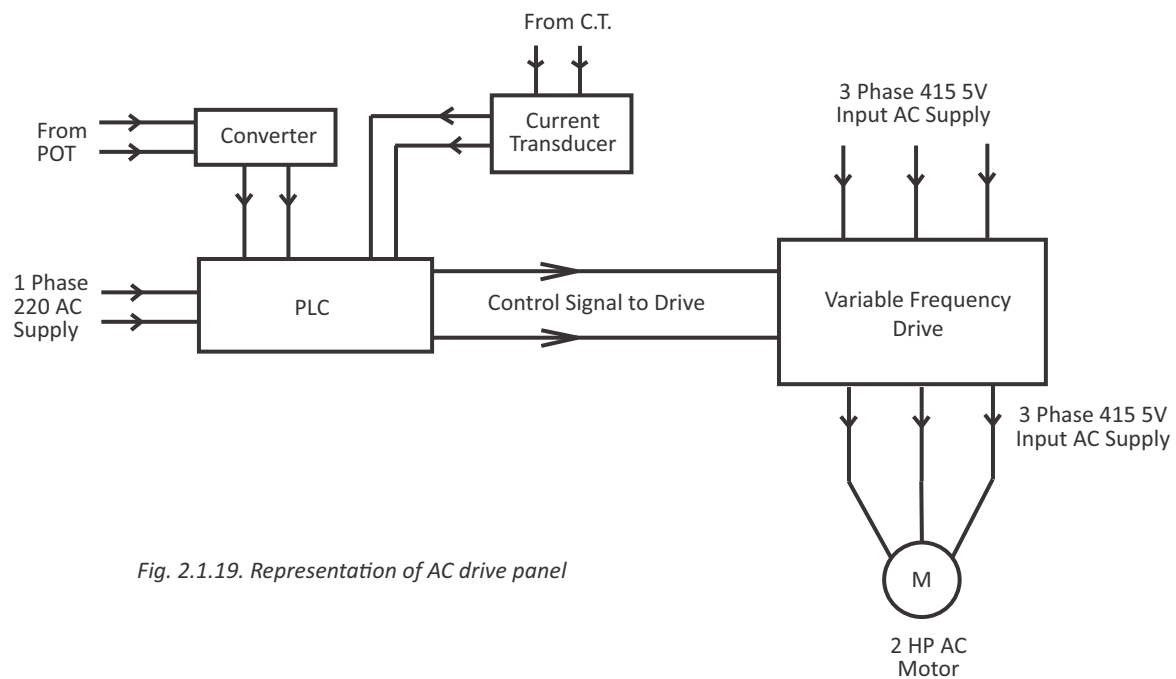

Fig. 2.1.19. Representation of AC drive panel

Elaborate

Following is a comparative study done for AC Drive Wire Saw and DC Motor Wire Saw in marble mines in the Rajsamand area.

S. No.	Parameters	Wire Saw with AC Drive	Wire Saw with DC Drive
1	HP for Wire Saw	60 HP	60 HP
2	Life Segment per bead Chain	16000 feet	23000 feet
3	Cutting Speed	85 sq. ft/hour	50 sq. ft/hour
4	Average Current	46 Amp (10% of cut at 30 Amp, 80% of cut at 50 Amp, 10% of cut at 30 Amp)	40 Amp
5	Voltage	415 V	415 V
6	Size of Cut	1500 Sq. feet	1500 Sq. feet
7	Time for once Cut	$1500/85 = 17.64$ hours	$1500/50 = 30$ hours
8	Power Consump.	$P = 1.732 \times VI \cos\phi$ Assuming Power Factor = 1 $P = 1.732 \times VI$ $P = 1.732 \times 415 \times 46 = 33.06$ KW	$P = 1.732 \times VI \cos\phi$ Assuming Power Factor = 1 $P = 1.732 \times VI$ $P = 1.732 \times 415 \times 40 = 28.75$ KW
9	Time	17.64 Hours	30 Hours
10	Consump. Unit	$(33.06 \text{ kw}) \times 17.64 = 583.24$ Units	$(28.75 \text{ kw}) \times 30 = 862.5$ Units
11	Distance	$= 279.26$ Units	-
12	Power Saving	$= 0.186$ Units	-
13	Monthly Saving	$7 \text{ Lakh} \times 6.3 \times 0.186 = \text{Rs. } 8.21 \text{ lakh}$	-
14	Cutting Cost	$2000 \times 31/16000 = 3.8$ Rs./Sq.ft	$2000 \times 31/23000 = 2.70$ Rs./Sq.ft
15	Power Cost	$583.24 \times 6.3/1500 = 2.45$ Rs./Sq.ft	$862.5 \times 6.3/1500 = 3.65$ Rs./Sq.ft
16	Manpower cost	40% less than DC = 2.10 Rs. / Sq. ft	= 3.50 Rs. Sq. ft.
17	Repair & Maint	40% less than DC = 1.80 Rs. / Sq. ft	= 3.00 Rs. Sq. ft.
18	Water Consump.	40% less than DC due to more speed	
19	Total Cost	10.15 Rs. / Sq. ft.	12.85 Rs. / Sq. ft
20	Saving	2.70 Rs. / Sq. ft.	
21	Monthly Saving	$70,000 \times 2.7 = \text{Rs. } 18.90 \text{ Lakh}$	

From this study we can see that the operation cutting speed and cutting cost for Wire Saw with AC Drive is more profitable as compared to Wire Saw with DC Motor.

2.1.6.3: Depending on the Composition of Marble

Explain

Depending on the natural composition of the marble or stone, the following type of wire saw is also used.

1. Chain saw machine
2. Belt saw machine

The operation cost of these machines is high. Additionally, since the cutting blade of these machines is about 3.25 m only, it is possible to use these on blocks which are up to 3m high. This makes these machines difficult to be used in Indian scenarios.

Wire saws are also used in granite mines and limestone mines.

The wire saw machine occupies an important place in the mining of marble and other natural stone.

2.1.7: Types of Deposit Area

Say

To understand the use of mining machines, it is important to have an idea about the various kinds of deposit areas.

2.1.7.1: Flat Deposit Area

Explain

In a flat stone deposit area, the first block is removed by the following method shown below.

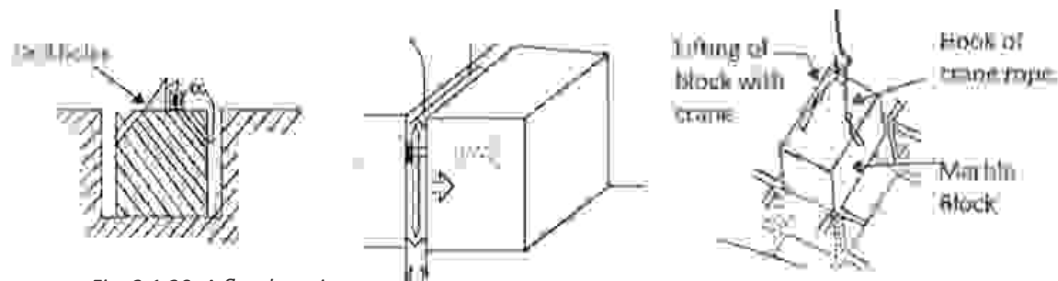

Fig. 2.1.20. A flat deposit area

Then 10-12 more blocks are removed and the area is expanded.

After this, a box is made on the lower surface and one more block is removed and the area is expanded. Similarly once again as shown below with multiple benches.

In the following figure, the benches made in the flat (deposit) mines are shown.

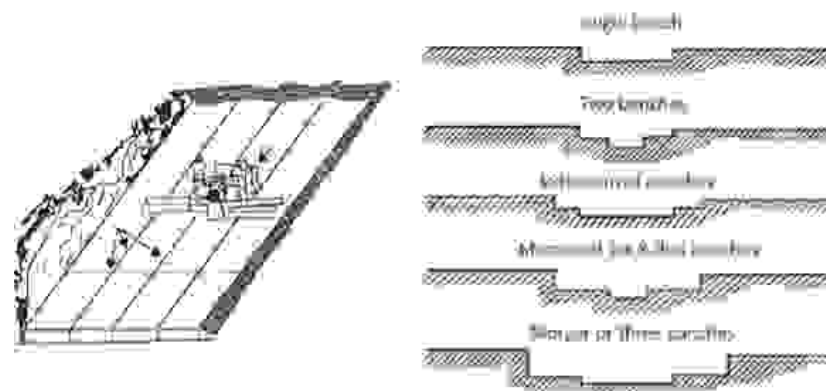

Fig. 2.1.21. Benches in flat deposit area

2.1.7.2: Inclined Deposit Area

Explain

In this method too, the blocks are removed as in a flat deposit area, but the benches are extended in the downward direction.

The following figure shows how benches in an inclined deposit are developed.

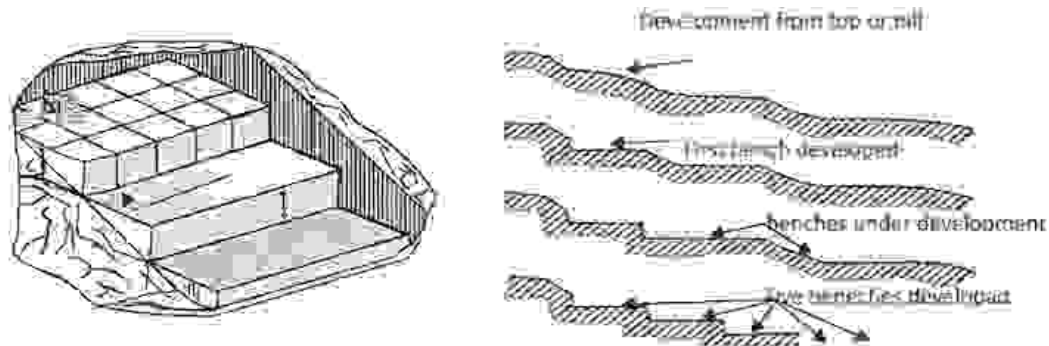

Fig. 2.1.22. Benches in An inclined deposit area

Following is an inclined deposit area.



Fig. 2.1.23. An inclined deposit area

2.1.8: Using a Wire Saw in Marble Mine

Demonstrate

In marble mines, both vertical and horizontal cuts are made using a diamond wire saw. Vertical and horizontal holes are made perpendicular to each other in order to make these cuts.

A diamond wire is threaded through these holes and mounted on the wheel of the wire saw, locked and rotated to cut.

The following figure shows vertical and horizontal cutting using a wire saw.

The following figure shows setting up the diamond segmented wire.



Fig. 2.1.24. Using the wires

A wire saw can be used for the following functions.

1. Making blind cuts to make gulleys. The following image shows a blind cut being made.

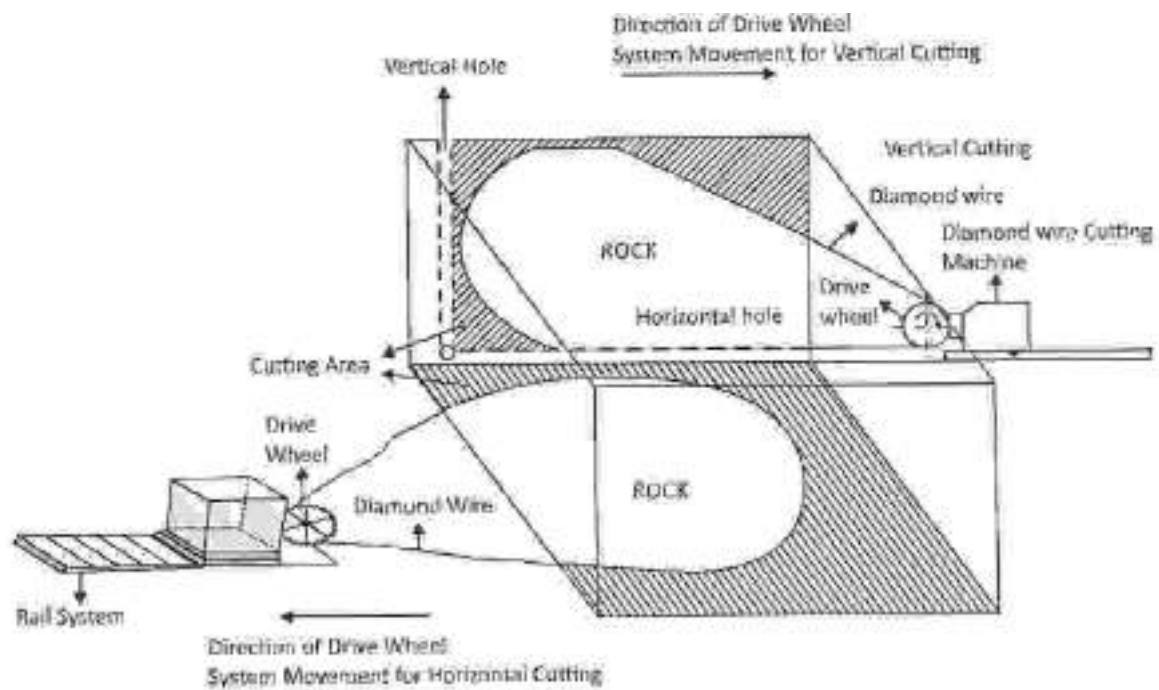

Fig. 2.1.25. Horizontal and vertical cutting

A wire saw can be used for the following functions.

1. Making blind cuts to make gulleys. The following image shows a blind cut being made.

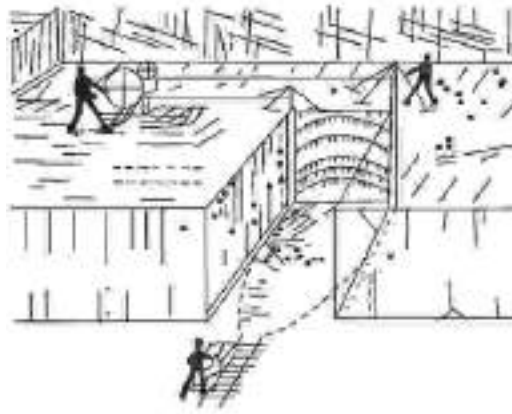

Fig. 2.1.26. Making blind cuts to make gulleys

2. Making different other kinds of cuts (horizontal, vertical, back cut) in order to demolish a marble mega block.

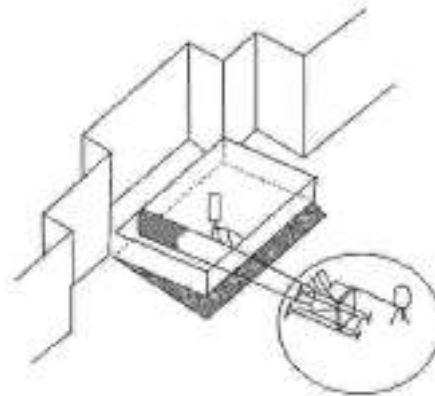

Fig. 2.1.27. Demolishing a mega block

The following picture shows a mega block being demolished.



Fig. 2.1.28. Demolishing a block

3. Making cuts for dressing marble blocks into almost finished block shapes. The following picture shows dressing of marble blocks.



Fig. 2.1.29. Marble blocks

4. Making cuts for splitting (sizing) of marble mega blocks. The following picture shows splitting of a marble block.



Fig. 2.1.30. Cutting the blocks

Activity

- Conduct a 'Making Diamond Segment for Wire Saw Activity'.
- Ask the students to make group of 5 students.
- Students have to Demonstrate Making Diamond Segment for Wire Saw Activity.
- One group of Students will have 120 minutes for preparing Demonstration. 60 minutes for Demonstration.
- Appreciate learning skill of students and do the corrections, if any something is wrongly done.

Activity	Time	Resources
Making Diamond Segment for Wire Saw Activity	2 Hours	Participant Handbook, Notebook, pen, Flipchart / Laptop, Base Wire, Diamond Segment and other Accessories

UNIT 2.2: Prepare the Wire Saw Machine for Operation

Unit Objectives

At the end of this unit, students will be able to:

1. Understand the importance of the Operator's manual and training
2. Understand the importance of performing regular inspections
3. Perform various steps to prepare the wire saw for use
4. Inspect the various parts of the machine before use
5. Report anomalies to the supervisor

Resources to be Used

- Laptop
- Projector
- White Board
- Marker
- Duster
- Details and Photos of Wire Saw Machine Parts
- Wire Saw Machine
- Field Visit to Marble Mine

Do

- Greet the participants for the day.
- Give Summary of previous Session.
- Ask for any doubts in previous Session.
- Acknowledge for their doubt-raising, if any. Clear the doubts.
- Give details of today's session and what they are going to learn.
- Encourage them to share their thoughts and doubts now and during process of this course.

2.2.1: Operator's Manual and Training

Ask

- What Operator's Manual for Wire Saw machine?
- Why Operator's Manual is required?

Say 

Every wire saw machine comes with an operator’s or user’s manual. The operator should read the manual in detail before beginning to operate.

Explain 

The Operator’s Manual includes detailed and important information about the machine and listed in the following figure:

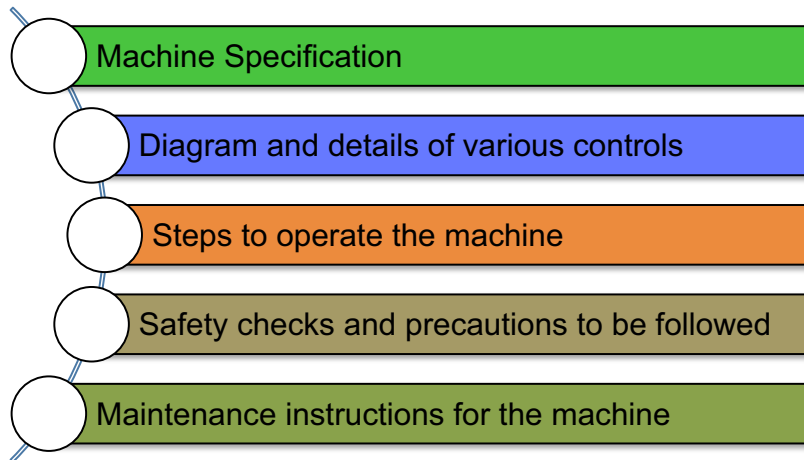

Fig. 2.2.1. Key points covered in an operator’s manual

The operator should also go through detailed training.

Look out for the below symbols in the Operator’s Manual. These signify areas which require special attention and a safety alert, failing which can lead to personal injury. The following figures shows different caution alert signs in a mine.



Fig. 2.2.2. Caution alert signs in a mine

2.2.2: Regular Inspection of Machine

Demonstrate 

The machine should be inspected regularly by the operator. Following are some advantages of inspecting the machine regularly according to the specified method:

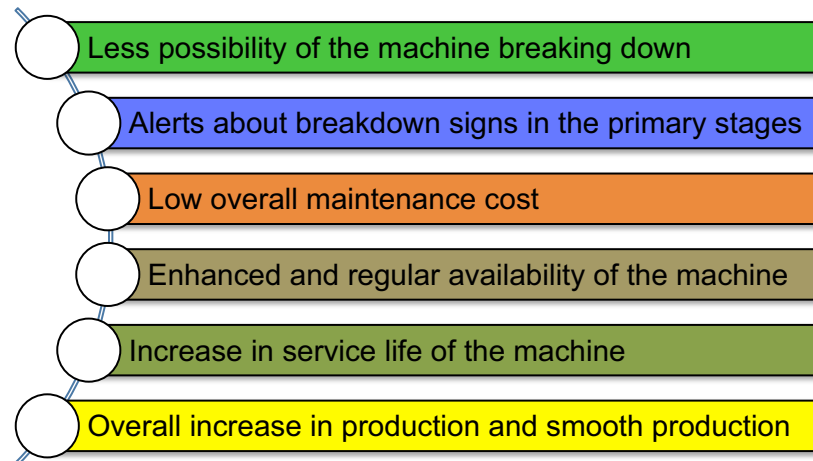

Fig. 2.2.3. Advantages of regular inspection

2.2.3: Preparing to Use Wire Saw Machine

Demonstrate

To prepare to use the wire saw machine in a mine / work area, we should ensure the following key points to keep in mind before reaching the area.

2.2.3.1: Before Reaching the Mine / Work Area

Elaborate

- Ensure you have had training on operation of the machine.
- Take necessary instructions and directions from your supervisor or engineer. Ensure you understand every instruction. If not, ask for clarity.
- Ensure you understand the safety directions from your supervisor well.
- Collect your job card.
- Make sure the safety equipment are in place, such as helmet, gumboot, gloves etc.
- Take up only the authorized machine.

2.2.3.2: On Reaching the Mine / Work Area

Elaborate

- Inspect the Wire Saw machine thoroughly, such as the wire, rubber ring of the wheel, pulley and other equipment. Refer to the next section for details on how to inspect.
- Inspect for any crack in the wheel, pulleys or wire.
- Inspect all the meters in the panel.
- Keep the wire saw in the proper place and on required elevation.
- Inspect the railing properly.
- Make arrangements for storage of water in appropriate place.
- Ensure safety guard facility.

2.2.4: Inspecting the Machine Before Use

Demonstrate



Before the machine is used, following are the types of inspections to be performed by the operator.

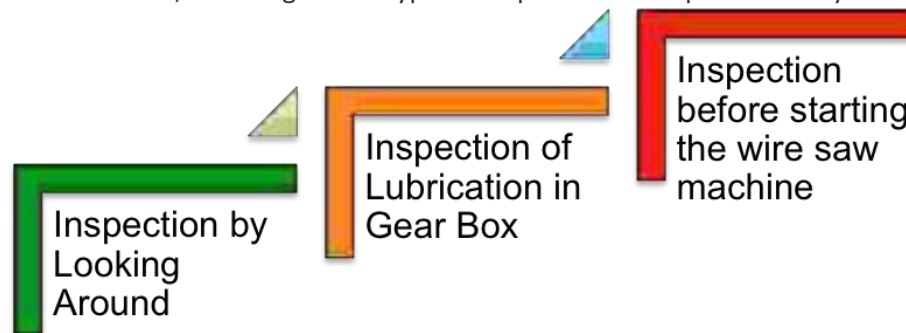

Fig. 2.2.4. Types of inspection

2.2.4.1: Inspection by Looking Around

Demonstrate



In the beginning of the shift, before operating the machine, the operator should look around the machine, and inspect it thoroughly.

Following is a checklist of some ways in which inspections are to be done by looking around.

- Inspect the place where the Wire Saw is going to be operated. Check if any cracks are present.
- Check if the safety guard is installed on the wire saw.
- Check if the rubber ring on the fly wheel is in good condition and not cut/broken anywhere.
- Check if the wire saw railing (travelling track) is in good condition and kept on level ground.
- Check if the diamond segmented chain made for cutting marble/natural stone is in working order.
- Check if the crimping on the sleeve of the diamond segmented chain wire is in good condition.
- Check if the pump used for cooling is in working order.
- Check if the facility of water for cooling of diamond segmented wire is available and cleaning of the cut has been performed and in working order.
- Check the guide pulley to ensure it is working properly.
- Check if the tools used for the machine are available. If some defect or malfunctioning is found, it should be rectified immediately.
- Check if the power supply cable coming to the electric panel and the cable connecting the electric panel and wire saw is not cut or broken anywhere.
- Check whether the panel is kept in a safe place.

Besides these, the following checks should also be made:

- The cover on the motor of the Wire Saw is closed properly.
- There are no other servicing tools or obstructions kept on the railing (travelling track).
- There are no unnecessary or without access people or equipment near the Wire Saw.

2.2.4.2: Inspection for Oil and Lubrication

Demonstrate

The following checks should be done to ensure oil and lubrication in the machine is in order.

- The oil level in the gear box installed for connecting the main pulley of the wire saw to the electric motor should be checked. If the oil is not sufficient, then the parts will not function properly, and will be worn out.
- Before you use the machine each time, gently lubricate the following components:



Fig. 2.2.5. Components to be lubricates

- Similarly, the water pump and the water hose pipe used for cooling the diamond segmented chain on the Wire Saw and cleaning the cut should be checked.

2.2.4.3: Preparation Before Operating Wire Saw

Demonstrate

Before the machine is made available for use, the following checks should be completed by the operator. Check the machine thoroughly according to all the checking rules listed as per the guidelines and as per the Operator's Manual.

Step 1: Checking the Control Panel

- The entire operation of the Wire Saw machine is done through the panel. Thus it is important to check the panel.
- Check if the control panel is working and if the holder, meters and switches on it are in good condition and working order.
- Switch on and off each switch to ensure they function properly and smoothly
- The voltmeter and ammeter on the panel should be checked to see if they are working properly and the hour meter must also be working properly.
- Inspect all the electricity wires from the control panel to the machine and check if any of them is cut, broken or spliced.

Step 2: Check the Fly Wheel

The fly wheel should be carefully checked. To do this:

- Rotate and check the fly wheel to see if it is rotating properly.
- Check the oil in the gear box
- Check the rubber ring on the fly wheel. The rubber ring is important because if the rubber ring is cut or broken, then the diamond segment is directly affected. That is why it is also important to replace the rubber ring from time to time.
- If the wheel has a bend, then the bend should be removed properly. If there is a bend in the fly wheel, then the rubber ring starts cutting from one side, and blocks that are cut become defective

Step 3: Checking the Guide Pulleys

- Check the guide pulleys along with the Wire Saw machine.
- They should be used according to the requirements of the cut.
- Check whether the pulleys are rotating properly.

Step 4: Checking the Diamond Chain

- Check the diamond segmented chain properly to see if it is in working condition before it is mounted on the fly wheel of the wire saw.
- The chain should not be disjointed, defective or broken.
- Any tool can get very hot on use. In case you are checking the machine after it has been used once, remember to touch sharp edges or any part only when you are sure it has cooled down.
- Wear gloves when removing or cleaning up chips and cutting debris. Chips or the wire can be very sharp and cause cuts.
- Before performing any service on the equipment, disconnect the power source. Follow all lockout procedures required at the work site.

Step 5: Checking the Railing (travelling track)

It is necessary to check the railing before mounting the Wire Saw machine on the railing, because if the railing is not straight the machine will not work properly, and it will have a unexpected effect on the rock segment.

- Make sure that the place where the Wire Saw is to be operated is level. If it is not level, then the ground should be leveled and alignment should also be proper
- Make sure the rail is not broken, does not have any unexpected obstruction or tools on it.

Step 6: Checking the water pump

- Check if proper provision is made for collecting the water used for cooling the diamond segmented chain and for cleaning the cut
- Check whether the water pump is working, foot valve has been installed, and a hose of appropriate length is available.

Additional checks

- Before use, gather complete information about the parts and tools used in the machine. Check and keep them in a specified place.
- When there is no need for the wire saw machine, store it properly. It is important to make sure that the wire saw machine is kept in a safe place, especially during blasting operations.

Tips 

Be Alert! Ensure you avoid injury during the pre-operation checks. Be careful of rotating parts, which can catch fingers, loose clothing, or long hair. Wait for engine and all moving parts to stop before completing your pre-operation check or doing any adjustments to the machine.

2.2.5: Safety Equipment while Preparing

Demonstrate 

Ensure you wear the safety equipment, as mandated by your organization while performing the checks. These are:

1. Protective clothing:

- Wear safety shoes.
- Avoid loose clothes or hanging clothing material.
- Wear gloves and helmets.

The following image shows examples of protective clothing.



Fig. 2.2.6. Safety gear

2. Eye and Hearing Protection:

- Wear impact-resistant safety goggles as mandated by your organisation.
- Machines and mining areas can produce loud noise. Wear hearing safety equipment to protect your hearing.

The following image shows example of safety goggles and hearing safety equipment.



Fig. 2.2.7. Safety - Helmet, Ear cap, goggles, gloves, shoes & jacket

2.2.6: Reporting to Supervisor

Demonstrate

In case of any malfunctioning, wires or controls not working, missing or broken parts, inform your supervisor or engineer immediately.

Note that any defect or abnormal condition can be quite serious and cause the following:

- Accident
- Wastage of Material
- Loss of Time

The following figure shows the effect of not reporting alerts:

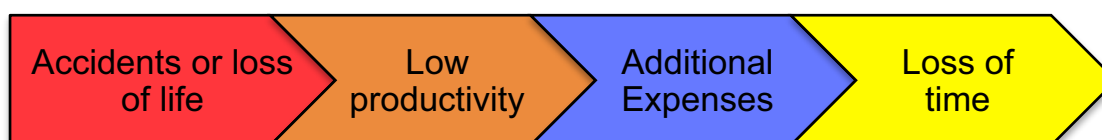

Fig. 2.2.8. Effect of not reporting alerts

Activity

- Conduct a 'Wire Saw Machine Preparation Activity'.
- Ask the students to make group of 5 students.
- Students have to Create Presentation on Wire Saw Machine Preparation.
- One group of Students will have 120 minutes for preparing demonstration. 60 minutes for demonstration.
- Appreciate identification skill of students and demonstrate correct machine preparation, if any step in demonstration is wrongly shown.

Activity	Time	Resources
Wire Saw Machine Preparation Activity	2 Hours	Participant Handbook, Notebook, pen, Flipchart / Laptop, Wire Saw Machine, Marble Quarry, Safety Equipment

Notes



Skil India
कौशल भारत - कुशल भारत



3. Perform the Wire Saw Operation

Unit 3.1 - Understanding Operation Standards

Unit 3.2 - Do's and Don'ts of Wire Saw Operation

Unit 3.3 - Operating Instructions

Unit 3.4 - Typical Issues and Troubleshooting

Unit 3.5 - Enhancing Productivity

Unit 3.6 - Ensuring Safety

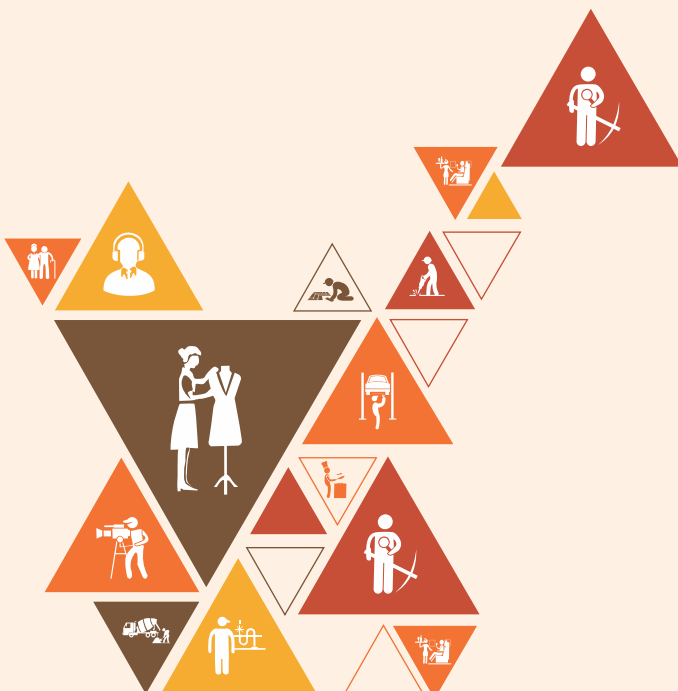

MIN/N0210

Key Learning Outcomes

At the end of this module, students will be able to:

1. Identify the standards to be maintained while operating a wire saw machine
2. List the do's and don'ts of wire saw machine operation
3. Follow instructions for various kinds of operations
4. Identify some typical issues that may arise and their solutions
5. Follow safety guidelines
6. Improve skills required to be an efficient wire saw operator

UNIT 3.1: Understanding Operations Standards

Unit Objectives

At the end of this unit, students will be able to:

1. Perform checks for all parts before operating a wire saw machine
2. Prepare the machine for operations
3. Set the machine
4. Install the diamond segmented wire for various types of cuts
5. Decide the amount of force required
6. Follow cutting standards for various kinds of cuts
7. Decide the kind of movement required for the wire

Resources to be Used

- Laptop
- Projector
- White Board
- Marker
- Duster
- Details and Photos of Wire Saw Machine Parts
- Wire Saw Machine
- Field Visit to Marble Mine

Do

- Greet the participants for the day.
- Give Summary of previous Session.
- Ask for any doubts in previous Session.
- Acknowledge for their doubt-raising, if any. Clear the doubts.
- Give details of today's session and what they are going to learn.
- Encourage them to share their thoughts and doubts now and during process of this course.

3.1.1: Startup Checks before Operation

Ask

- Is it ok to start machine without doing startup checks?
- What should be the check point before starting the machine?

Explain

Before beginning any operation with a wire saw machine, remember to perform these checks.

3.1.1.1: Checking all Parts of Machine**Demonstrate**

- Before the job is begun, the operator should personally inspect and verify the following so as to ensure normal working of the wire saw machine: Electric Panel, AC Main motor, AC Motor/DC motor, fly wheel, rubber ring, pulley and other associated machines/equipment.
- Inspect the flywheel rubber ring from time to time and replace it if necessary.
- Ensure that the flywheel casing hatch is opened only when the flywheel has stopped.
- Correct and tighten the guide pulley. Inspect and ensure that it is in working order and spinning freely.

3.1.1.2: Inspecting the Work Space**Demonstrate**

- Inspect the entire workspace carefully so that the machine can be safely operated.
- Before starting the wire saw machine, make sure the workspace is safe from dangers like falling stones, loose ground and overhang.

3.1.1.3: Inspecting the Electric Panel**Demonstrate**

- Keep the electric panel in a dry and safe place. In case its cable has joints please verify that the connection is intact.
- Ensure that you have full knowledge of the meters and indicators on the electric panel being used in the wire saw.
- Inspect the cable of the wire saw machine too. Ensure the cable of the wire saw is not submerged in the water.
- Check the holder and cable of the machine once more before it is started, and ensure that there are no exposed wires or loose joints; else there is a chance of electric shock due to water.

3.1.1.4: Inspecting the Diamond Wire**Demonstrate**

- Ensure that the diamond segmented wire provided is fully functional.
- Ensure the correct alignment of the machine, that the diamond segmented wire has the correct tension and pay special attention to cutting speed.
- At the time of obtaining the beads, ensure that the beads are adequate in quantity and also make a note of the same on their job card.
- Ensure that the diamond segmented wire joint is changed whenever necessary and that the length of the pressed joint is no more than 20-22 millimeters.

3.1.1.5: Inspecting the Water Availability

Demonstrate

- Ensure that proper quantity of water required for the cutting is available.
- Inspect the water pump and foot valve.

3.1.1.6: Checks While Moving the Machine

Demonstrate

- When the machine is being moved from one point to another, ensure that no part of the machine is hanging outside the tipper and also carefully load/unload the machine.
- Ensure that the jockey being used to lift or keep the machine is not cracked or broken.
- Put the railing in a level and ensure it is not obstructed.
- Ensure that a strong sling is being used for the wire saw to be lowered on its face or being lifted up.

3.1.1.7: Other Checks

Demonstrate

- Tell the colleagues about the task the operator is going to perform.
- Ensure that no person is standing on either side of the machine or in the arc of the movement of the wire as this may lead to an accident in case the wire is snapped.
- Ensure that safety equipment and procedures are not being bypassed at any time.
- Ensure that no unauthorised person is around the machine and trying to operate it.
- Ensure that the wire saw bench settings or the shifting necessary for blasting is carefully done.

3.1.2: Preparation Steps before Machine is Operated

Demonstrate

Steps for Machine Preparation

Following preparations need to be made before the wire saw machine is operated.

- Before the machine is started, the operator should be in full readiness and should not have mental tensions of any kind.
- Operator must have full knowledge of all the tools that are needed for operating the machine, and the same should be kept accessible in a toolbox.
- The location where the machine is to be operated should be ensured to be even.
- In case the floor is uneven then please ensure that it is made even and check that the alignment is in order.

After all these things are ensured, only then the machine is in a position to be operated.

3.1.3: Steps for Setting the Machine

Demonstrate

Steps for Setting the Machine

To begin operation with the wire saw on a stone block, the machine should be set in the same line as the level hole, such that the fly wheel is correctly aligned with the level hole.

The rail of the machine should be set parallel to the level hole.

If the machine is set in an incorrect line, then the cut will not be straight and may also result in damaging the block. Additionally, the speed of the diamond beads will be reduced due to this and they will be worn out on one side, thus in turn reducing the speed of the cutting.

When the machine is being set, please make sure that the machine is level using a spirit level, and that the fly wheel is straight.

3.1.4: Steps for Installing Diamond Segment Wire

Demonstrate

Installing the diamond segmented wire on the fly wheel is a crucial part of getting the wire saw machine ready for operation. Following are some of the things to keep in mind while installing the wire.

3.1.4.1: Steps for Small Cuts

Demonstrate

- Make sure that the wire on the top and the bottom are in the same line.
- Using a plumb line, taking into consideration the bottom wire, make a channel on the stone and keep the top wire in between the channel.

3.1.4.2: Steps for Big Cuts

Demonstrate

Keep the pulley on the top surface of the cut. This has the following advantages:

- The cable will rub less against the stone, and thus the rubber lining on the wire fly wheel will be less worn out.
- We will get straight cuts with this, and the diamond segment beads will also wear out less.
- The diamond segment beads will rotate properly, and they will not wear out only on one side.

The following image shows the position of the pulley for cutting a wire saw.



Fig. 3.1.1. Use of pulley

3.1.5: Application of Force

Demonstrate

Application of force in a controlled manner is important while operating a wire saw.

To ensure the rotation of the diamond segment beads while cutting the stone slabs, force is applied to the wire in advance. This force is about of 1 to 1.5 times per meter.

The rotation of the diamond segment beads should be checked from time to time using the following techniques:

1. Peg or clip technique: Put a clip on the wire and pull the wire with hand from the top, while rotating. Check the rotation of the clip. For a 3m length cut, the clip should be rotated 1 or 1.5 times. Perform this check again for the top wire in the same way. Repeat this check after cutting and rejoining the wire, so that the wearing out of the diamond segment beads only on one side can be avoided and their life span can be increased.

The following figure shows clip technique:

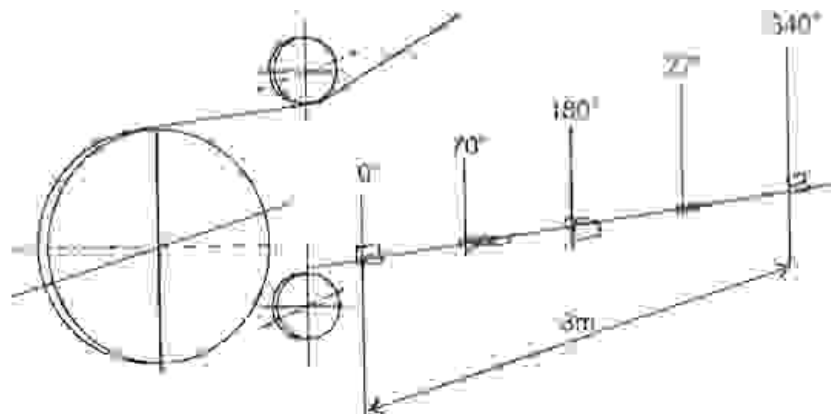

Fig. 3.1.2. Application of force using clip technique

2. Paint technique: Paint half of the circumference of the diamond segmented wire, about 60 to 70 cm, with a fast drying paint. Start the machine. If the painted portion is seen irregularly, then appropriate force should be given before starting so that the diamond segmented wire rotates properly. This is a good way to check the rotation of the diamond segment beads and its helps in prolonging the life span of the beads.

3.1.6: Cutting Standard

Elaborate



The performance of the diamond segmented wire is directly affected by the state of cutting. The following factors affect the performance of the diamond wire:

- Type of marble being cut.
- Type of cut (vertical, level, perpendicular-vertical)
- Cutting parameters, ie back speed of the machine, wiring and circumference speed.
- Setting the machine.

3.1.6.1: Back Speed of the Machine

Explain



If the back speed of the machine is too little, then the diamond beads get polished and it becomes difficult to cut. If the back speed of the machine is too much, then the diamond beads can come out and thus get worn out quickly.

The back speed should be determined on the basis of the kind of cut, beginning of the cut and ending of the cut.

3.1.6.2: Speed of the Circumference

Explain



Circumference speed is one of the factors that affect the performance of a wire saw. Too much speed polishes the beads and too little speed wears out the beads faster. The speed should be reduced at the beginning and ending of the cut.

3.1.6.3: Ending the Cut

Explain



It is necessary to reduce the back speed of the machine towards the end of the cut because the wire is operating at lesser radius at that time.

It is always better to remove the main wire at this time and use an old worn out wire so that the main wire is protected.

3.1.6.4: Watering

Elaborate



Watering is used to cool the segment and clean the cut. Hence, always ensure that the water supply is in appropriate amount during cutting.

If there is not enough water supply then the wire vibrates and the beads may come out.

Extra water however can polish the beads while less water can open the beads, which reduces the life span of the beads. The following figure shows the watering process.

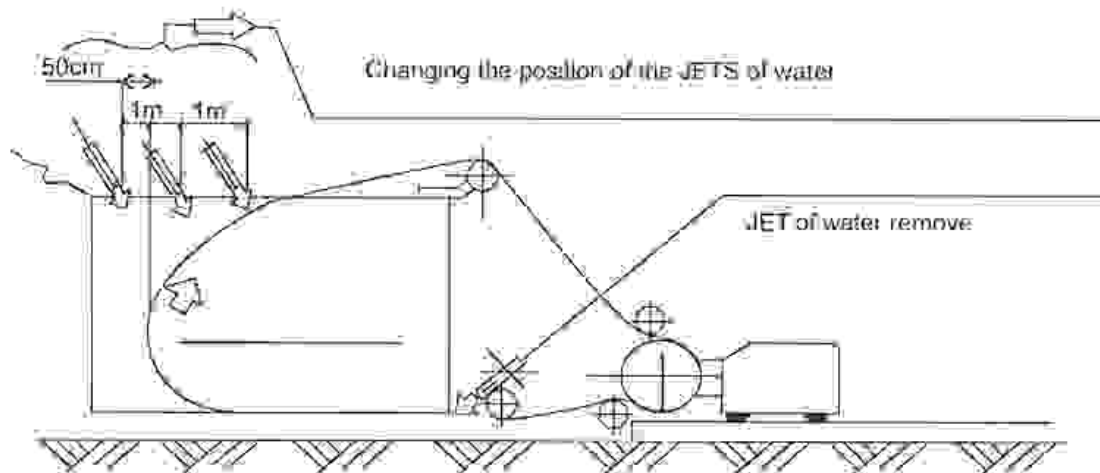

Fig. 3.1.3. Watering process

3.1.7: Movement of Diamond Wire

Demonstrate



Normally, the movement of the fly wheel of the diamond segmented wire is linear as shown in the figure:

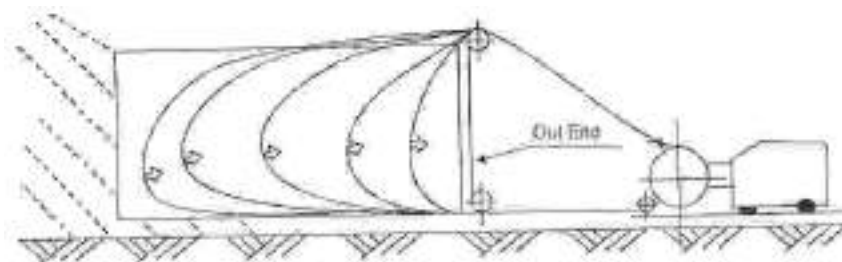

Fig. 3.1.4. Movement of fly wheel in a linear way

However, in some places, that diamond segmented wire is twisted in a loop, as in the number 8 shape on the fly wheel. Due to this, there is more contact between the fly wheel and diamond segmented wire. As a result, more force is available to the diamond segmented wire thus resulting in increased rate of cutting.

In this process care should be taken that the wires don't rub against one another and there is no damage to the wire. The following figure shows the movement in the shape of number 8.

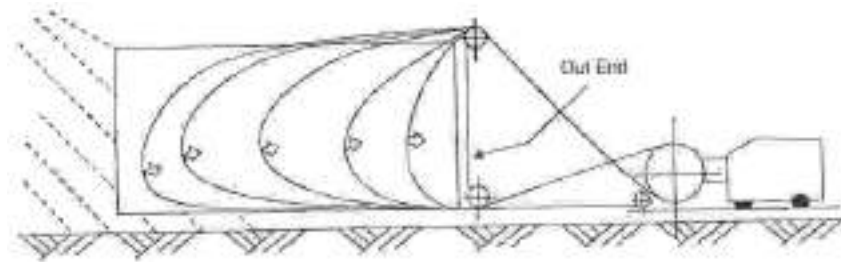

Fig. 3.1.5. Movement in 8 shape

Activity-1

- Conduct a 'Wire Saw Machine Check up Activity'.
- Ask the students to make group of 5 students.
- Students have to Demonstrate Wire Saw Machine Check up.
- One group of Students will have 60 minutes for creating presentation. 30 minutes for presentation.
- Appreciate learning skill of students and tell correct Check up Activity, if any Wire Saw Machine Check up Activity is wrongly quoted.

Activity	Time	Resources
Wire Saw Machine Check up Activity	2 Hours	Participant Handbook, Notebook, pen, Flipchart / Laptop, Wire Saw Machine, Marble Quarry

Activity-2

- Conduct a 'Wire Saw Machine Set up Activity'.
- Ask the students to make group of 5 students.
- Students have to Demonstrate Wire Saw Machine Set up.
- One group of Students will have 60 minutes for preparation. 30 minutes for demonstration.
- Appreciate learning skill of students and tell correct Set up Activity, if any Wire Saw Machine Set up Activity is wrongly quoted.

Activity	Time	Resources
Wire Saw Machine Setup Activity	2 Hours	Participant Handbook, Notebook, pen, Flipchart / Laptop, Wire Saw Machine, Marble Quarry

UNIT 3.2: Do's and Don'ts of a Wire Saw Operation

Unit Objectives

At the end of this unit, students will be able to:

1. List the do's and don'ts of handling the machine
2. List the responsibilities of a wire saw operator

Resources to be Used

- Laptop
- Projector
- White Board
- Marker
- Duster
- Details and Photos of Wire Saw Machine Parts
- Wire Saw Machine

Do

- Greet the participants for the day.
- Give Summary of previous Session.
- Ask for any doubts in previous Session.
- Acknowledge for their doubt-raising, if any. Clear the doubts.
- Give details of today's session and what they are going to learn.
- Encourage them to share their thoughts and doubts now and during process of this course.

3.2.1: Things to Keep in Mind

Ask

- What are the activities which should be avoided during Wire Saw machine Operation?
- What are the activities which should be done during Wire Saw machine Operation?

Say

Normally, the Wire Saw is used in rocky areas, where the conditions are difficult. So, the operator should take extreme care while operating the machine, so that there are no accidents and the machine is not damaged.

If the machine is operated in a careful manner, the production costs can be minimized, accidents can be prevented, and the cutting rate can be increased, thus increasing production.

Explain

The safety precautions can be classified into three categories:

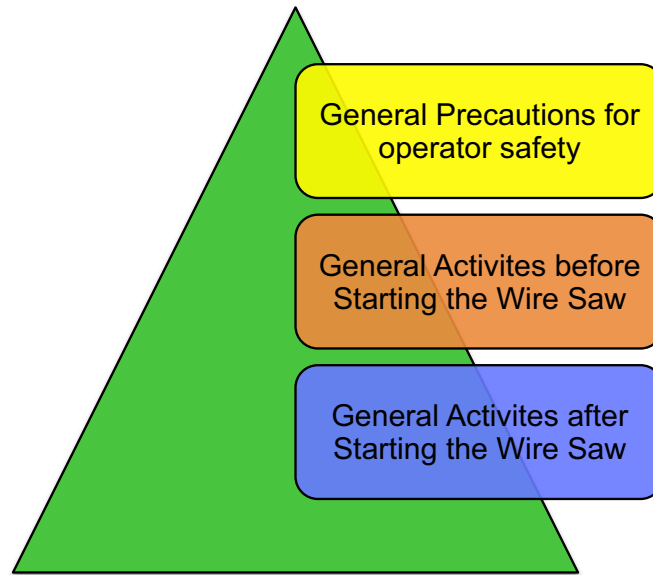

Fig. 3.2.1. Safety precautions in wire saw

These includes the following considerations:

- Rock condition, existing cracks, etc.
- Precautions related with machines operating in the surrounding.
- Precautions related to electricity supply.
- Precautions while working in the rain.
- Precautions to be taken when shifting the Wire Saw from one place to another.

The following figure shows transferring a wire saw from one place to another.



Fig. 3.2.2. Transporting a wire saw machine

3.2.2: Do's and Don'ts

Explain

Given below is a list of do's and don'ts for safety during wire saw operation in the above conditions:

Do's	Comments
Wear proper fitting clothes, safety helmet, gumboot	This protects you from falling objects and electric shock.
Use Safety goggles	Your eyes are protected
Use gloves	You are protected from electric shock and cut, broken wires.
If it is too noisy, use ear plugs	Protects your hearing
Always be alert during operation.	Accidents occur due to carelessness
Be informed about all the safety equipment in different location	You can use them instantly when needed.
Learn how to use the safety feature on the machine.	You can use them instantly when needed.
Always operate the wire saw with a speed such that the tension in the chain remains constant	If the tension varies, the wire breaks.
Always pay attention to the panel and work area	Accident can occur due to carelessness.
Don'ts	Comments
If you are tired, don't operate the wire saw	You can lose concentration any time, leading to fatal accident. broken wires.
Do not operate the machine when intoxicated	You can lose your control over the machine.
Do not operate the wire saw until you have completed the pre-operation checks	Accidents occur due to carelessness
Do not talk to anyone while operating the machine	you can lose concentration any time and accident can occur
If see a crack in the face being cut, don't operate the wire saw.	Accident can occur due to rock falling from the face

Don'ts	Comments
Do not operate the machine in places where there is less air circulation	this can affect your breathing
Always operate the machine with safety guard	If it is not installed, accident can happen
Do not let any unauthorized person run the machine	Accident can occur due to this

3.2.3: Responsibilities of a Wire Saw Operator

Say

Following is a list of responsibilities of the wire saw operator after starting the machine, as well as before and after stopping the machine.

3.2.3.1: After Starting the Wire Saw

Elaborate

After the machine is started, the operator should concentrate on the following:

- Pay attention to the ampere meter of the wire saw machine and operate the machine at the appropriate speed as prescribe and discussed. While the machine is running, keep an eye on voltmeters and ammeters as variations in the same may cause the motors to burn.
- Not leave his place of work.
- Not let any unauthorized person come near the machine.
- If cutting is not being done properly, turn off the wire saw before replacing or checking the tyre.
- Not use a crowbar to push the wire saw back.
- Neither operator nor any helper sleeps at the work place.
- Not let any labourer or employee sit on the wire saw cable.
- Not lean against the control panel or let anyone lean against it.
- Not let any labourer or colleague sit at the edge of the bench.
- If there is any technical problem, notify the authorized official immediately.
- Not send any colleague to attach a water pipe in an unsafe or dangerous place.
- Not bypass the safety equipment or safety method installed on the machine and machine panel.
- Not let any colleague or labourer to sit in the shade of or around a marble block.
- If there are any unusual sounds coming from the wire saw motor, shut it down immediately and have it checked.
- Connect the water pump connection to the Wire Saw motor only through a plug.
- Start the cut with the wire Saw machine only after the safety guard is installed and make sure that safety equipment are readily available nearby.

3.2.3.2: Before Turning off a Wire Saw

Explain



The following points should be kept in mind before turning off a wire saw:

- Loosen the diamond wire a little without load.
- Turn off the water supply.
- Turn off the supply from the panel.
- Use the tripping device. Do not operate directly.
- Note the time, tripping and technical problems etc. on the job card.
- In event of any danger, notify the superior official immediately.

3.2.3.3: After Turning off a Wire Saw

Explain



The following points should be kept in mind after turning off the wire saw.

- Submit job card to the authorized official. Update the job card with details of the work done after the shift has ended and also must make the entry about the working state of the machine.
- After the shift is complete, discuss and provide complete information for the day to the supervisor
- Keep all the equipment in a safe place once work is complete.

The following figure shows a wire saw machine kept in a safe place post operation-



Fig. 3.2.3. Wire saw machine kept in a safe place

3.2.3.4: Other Responsibilities of a Wire Saw Operator

Elaborate



The wire saw operator should keep in mind the following:

- When leaving the workspace, hand over the machine only to a skilled and experienced operator. Do not allow unauthorised persons to handle the machine.
- After completing the work, return the machine to the right location and also note the time and other relevant details in the job card.

- In case of faults in electrical equipment, get them repaired only by authorised technicians.
- Make use of necessary guide pulleys.
- After cutting the diamond segmented wire, return the wire to the relevant department.
- Ensure that the machine is properly set on its foundation, otherwise the collar of the wheel or rubber ring may get cut.
- The chuck nuts of the wheel on the machine should be tightly fastened. If they are found to be loose, work start only after they are tightened, else the wheel moves in and out.
- After cutting is complete, please wash the machine thoroughly with water.
- The railing associated with the machine should not have any bend in it. If there is a bend, please rectify it and ensure that the railings are kept clean; otherwise it leads to an unnecessary load on the drive motor. If the railing is bent then it is possible that the cut may also not be in a straight line.
- Have the wire saw wheel rubber ring replaced in case it is worn out.
- Monitor the supply voltage reading in the wire saw panel voltmeter. It should be between 380 to 440 volts.
- Check the main pulley in the wire saw machine by rotating it with hands. The pulley should be able to be rotated freely.
- On the 60HP and 40HP machines, do not load more than 60 ampere and 40 amperes respectively.
- Do not play around with the panel and keep the panel away from the edge of the bench.
- After finishing the cut, please inform the electricity department to shut down electric supply.

3.2.3.5: Instruction for AC Drive Wire Saw

Explain

Following are some things to be kept in mind, in case of an AC drive wire saw.

- Firstly start the panel and check the ampere meter etc.
- The AC drive machine should only be operated in auto mode.
- The speed of operating the AC machine should be decided as follows :
The Following information shows speed of operating the AC machine -
A- Starting a new cut - 30-35 amperes for approximately 30 minutes
B- Run continuously after 30 minutes - 60-65 amperes
C- Cut is near completion - 30-35 amperes for approximately 45 minutes
D- If block rock, quartz is used or if the diamond wire bead are weak - 50-55 amperes. Do not run at 60-65 amperes.

Activity

- Conduct a 'Post Wire Saw Activity'.
- Ask the students to make group of 5 students.
- Students have to Demonstrate Post Wire Saw Activity.
- One group of Students will have 60 minutes for preparation. 30 minutes for demonstration.
- Appreciate identification skill of students and tell correct Post Wire Saw Activity, if any Post Wire Saw Activity is wrongly quoted.

Activity	Time	Resources
Post Wire Saw Activity	2 Hours	Participant Handbook, Notebook, pen, Flipchart / Laptop, Wire Saw Machine, Marble Quarry

UNIT 3.3: Operating Instructions

Unit Objectives

At the end of this unit, students will be able to:

1. Understand how to create a gully
2. Understand how to cut a mega marble block
3. Understand how to dress or split a marble block

Resources to be Used

- Laptop
- Projector
- White Board
- Marker
- Duster
- Details and Photos of Wire Saw Machine Parts
- Wire Saw Machine

Do

- Greet the participants for the day.
- Give Summary of previous Session.
- Ask for any doubts in previous Session.
- Acknowledge for their doubt-raising, if any. Clear the doubts.
- Give details of today's session and what they are going to learn.
- Encourage them to share their thoughts and doubts now and during process of this course.

3.3.1: Steps for Cutting a Gully

Ask

- What is cutting gully in Wire saw operation?
- How to cut a Mega Marble Block?

Demonstrate

Following are the instructions for creating a gully using a wire saw, in order to apply a blind cut -

- For applying a blind cut, ensure that two 7 inch diameter holes created using an LM drill.
- The depth of the holes should be 10-15% more than the height of the face so that the cut is straight at the bottom.

- Inspect the pilot and other channel section which are to be inserted in the holes, to ensure that they are in proper condition and that the tools necessary for joining them are readily available.
- Check if the pulley in the pilot section is rotating freely and that the seal is intact. (The pulley rotates on self-lubricating bearings).
- Check the length of the pilot channel section and other sections by aligning them and ensure that is 3 to 4 feet more than the hole depth. Place the wire saw at the appointed place on the railing.
- Using a crane and by threading the base wire on the pulley, lower the pilot channel section into the hole. Fasten this using a vertical guide pulley on the upper surface of the stone face. Take one end of the base wire over the pulley, towards the wire saw.
- Use the crane and lower the second channel section into the hole on the side of the wire saw by fastening the base wire around the pulley. Fix this also to the upper surface of the face with an incline pulley.
- Take the base wire onto the wire saw flywheel to check if the wire is rotating freely on the pulley.
- Crimp the diamond segmented wire together with the base wire. Replace the base wire in the hole with this crimped wire and load it onto the flywheel.
- Remove and separate the base wire and crimp it with the diamond segmented wire.
- Without using the base wire, the diamond segmented wire should be threaded onto the channel section pulleys and then loaded and crimped onto the wire saw flywheel. This reduces the risk of the diamond segmented wire sliding off the pulley.
- Before the wire saw is started, make sure that the safety guard is in place.
- To cool the diamond segmented wire down and to ensure that the slurry in the cut is removed, ensure that the water, hose pipe and water pump arrangement is in working order.
- Place the electric panel in a secure space, connect the electric supply and check the connections.

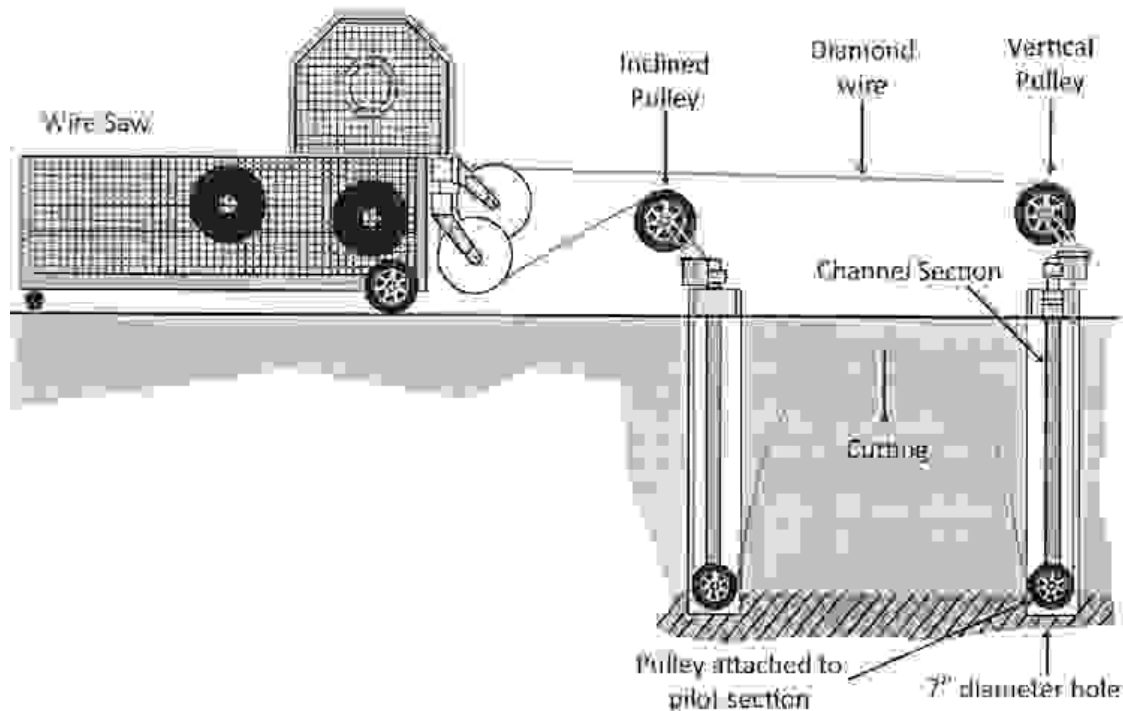

Fig. 3.3.1. Cutting with saw

3.3.2: Steps for Blind Cut for Horizontal (Bottom) Cut

Demonstrate

Steps for Making Blind Cut

In marble mines, in addition to using the blind cut method to make vertical cuts for gulleys, the blind cut method is also used to make horizontal (bottom) cuts.

- For this, two 12 inch wide holes are made.
- The channel sections to be placed in these holes have a pilot section which has two pulleys— one horizontal and one vertical.
- A diamond segmented wire is threaded around these two pulleys and then loaded onto a flywheel of the wire saw and rotated.
- This wire cuts rocks in the horizontal plane and frees the block from the bottom.

Arrangement of Pulleys is shown in following figures



Fig. 3.3.2. Blind cut methods

Fig1: Double pulley arrangement used for making a bottom cut using a blind cut method, fig 2: Single pulley arrangement used for making a vertical cut using the blind cut method.

3.3.3: Steps for Cutting a Mega Marble Block

Demonstrate

Steps for Cutting a Mega Marble Block

Following is the work procedure for cutting a mega marble block using a wire saw machine.

- Inspect the face at which the wire saw machine is to be operated. Check for any cracks present.
- Choose the wire saw according to the length and breadth of the mega block to ensure that the big machine is not used for a small cut, and a small machine is not used for a big cut.
- The alignment of the machine while placing it on the foundation should be correct, else the collar of the wheel and rubber ring may be cut.
- Ensure that there is a safety guard placed on the wire saw.
- Neither of the chuck nuts on the flywheel shaft of the machine should be loose. If they are loose please ensure that they are tightened before starting the machine, otherwise the flywheel will keep moving in and out.

- The machine should only be started after checking the holder and cable, there should not be any open wires and loose joints otherwise it is possible that the water may lead to an electric shock.
- The machine should have two guide pulleys or two guide Ts. In case two guide pulleys are not available, then one guide pulley and two guide Ts should be in place.

The following figure shows a wire saw making a reverse cut.



Fig. 3.3.3. Wire saw making reverse cut

Before loading the diamond wire, the machine should be run empty once without wires.

- Before running the wire saw, the diamond segmented wire should be given adequate forward force.
- The hoist used for lifting or lowering the machine should be checked to make sure it is not snapped or frayed.
- The electric panel should be placed at a secure place.
- While the machine is in operation, keep an eye on voltmeter and ammeter as the motor may burn if the voltage/current fluctuates too much.
- Please ensure that no person is standing behind the machine, since there is a danger of an accident in case the wire snaps.
- The railing alongside the machine should not have any bend in it.
- Both gear boxes should have an adequate quantity of gear oil.
- The rubber ring in the wire saw should be changed in case it gets worn out.
- After cutting is complete, wash the machine thoroughly with water.

3.3.4: Steps for Dressing / Splitting a Marble Block

Demonstrate

Steps for Dressing / Splitting a Marble Block

Following is the work procedure for dressing/splitting a marble block using a wire saw.

- Always use a 20 HP wire saw for dressing/splitting a marble block.
- Only one block should be attempted to be cut at a time. Trying to cut 2 or 3 blocks at the same time takes a longer duration.
- Immediately before operating the wire saw, do not forget to use the iron safety guard, which ensures your personal safety and also protects you from the water spray.
- For applying a dressing cut, place the block on a level surface such that the diamond wire can pass from below easily.
- Before placing the wire saw machine on the railing, please check the railing for any bends, otherwise the machine will not operate properly and will damage the segment. Sometimes, the wire saw railing is permanently fixed so that no time is wasted in ensuring the alignment of the railing.
- Pulleys can also be used in a dressing cut. If pulleys are used please make sure that the wire saw pulley, stand pulley and the proposed cut in the block are exactly in one line and also that the pulley is rotating freely.

Two types of pulley stands are available. The choice should be made as per the requirement. One is the fixed pulley stand. The other is movable, in which the pulley can be bent in any angle, and is useful for big blocks, where the wire saw alignment can be made using a pulley.

- Keep the pulley stand very close to the block and place the pulley on the stand above the level of the block.
- Fix the pulley stand on the ground after levelling it with a spirit level. Ensure it is firmly fixed.
- Before beginning the cut, make a small depression on the edges of the block for the wire. Ensure that they are perpendicular to each other and its width is equal on the upper and lower surface of the block, which will ensure that the block will be properly cut. Use the wire into the depression so that it deepens.
- Before joining both ends of the wire, make notches in the wire, at the rate of approximately 1.5 notches per meter of wire.
- While operating the wire saw, make sure the water supply is such that the cut receives water continuously and that the water moves ahead as the cut progresses.
- The slurry that comes as a result of the wire saw cutting should be collected periodically so that the clean water may be recycled and reused.

The following picture shows a block dressing.



Fig. 3.3.4. Marble block dressing

Activity-1

- Conduct a 'Cutting a Gully Activity'.
- Ask the students to make group of 5 students.
- Students have to do a demonstration on Cutting a Gully Activity.
- One group of Students will have 120 minutes for preparing for demonstration. 60 minutes for demonstration.
- Appreciate learning skill of students and tell correct Activity, if any Cutting a Gully Activity is wrongly demonstrated.

Activity	Time	Resources
Cutting a Gully Activity	2 Hours	Participant Handbook, Notebook, pen, Flipchart / Laptop, Wire Saw Machine, Safety Equipment, Marble Quarry

Activity-2

- Conduct a 'Cutting a Mega Marble Block Activity'.
- Ask the students to make group of 5 students.
- Students have to do a demonstration on Cutting a Mega Marble Block Activity.
- One group of Students will have 120 minutes for preparing for demonstration. 60 minutes for demonstration.
- Appreciate learning skill of students and tell correct Activity, if any Activity is wrongly demonstrated.

Activity	Time	Resources
Cutting a Mega Marble Block Activity	8 Hours	Participant Handbook, Notebook, pen, Flipchart / Laptop, Wire Saw Machine, Safety Equipment, Marble Quarry

Activity-3

- Conduct a 'Cutting a Blind Cut for Horizontal (Bottom) cut Activity'.
- Ask the students to make group of 5 students.
- Students have to do a demonstration on Cutting a Blind Cut for Horizontal (Bottom) cut Activity.
- One group of Students will have 120 minutes for preparing for demonstration. 60 minutes for demonstration.
- Appreciate learning skill of students and tell correct Activity, if any Activity is wrongly demonstrated.

Activity	Time	Resources
Cutting a Blind Cut for Horizontal (Bottom) cut Activity	2 Hours	Participant Handbook, Notebook, pen, Flipchart / Laptop, Wire Saw Machine, Safety Equipment, Marble Quarry

Activity-4

- Conduct a 'Dressing / Splitting a Marble Block Activity'.
- Ask the students to make group of 5 students.
- Students have to do a demonstration on Dressing / Splitting a Marble Block Activity.
- One group of Students will have 120 minutes for preparing for demonstration. 60 minutes for demonstration.
- Appreciate learning skill of students and tell correct Activity, if any Activity is wrongly demonstrated.

Activity	Time	Resources
Dressing / Splitting a Marble Block Activity	2 Hours	Participant Handbook, Notebook, pen, Flipchart / Laptop, Wire Saw Machine, Safety Equipment, Marble Quarry

UNIT 3.4: Typical Issues and Trouble Shooting

Unit Objectives

At the end of this unit, students will be able to:

1. Identify some typical issues that may arise
2. Understand the importance of the guide pulley
3. Identify key issues with the wire saw panel
4. Identify some common problems and their solutions

Resources to be Used

- Laptop
- Projector
- White Board
- Marker
- Duster
- Details and Photos of Wire Saw Machine Parts
- Wire Saw Machine

Do

- Greet the participants for the day.
- Give Summary of previous Session.
- Ask for any doubts in previous Session.
- Acknowledge for their doubt-raising, if any. Clear the doubts.
- Give details of today's session and what they are going to learn.
- Encourage them to share their thoughts and doubts now and during process of this course.

3.4.1: Some Typical Factors

Ask

- What is trouble shooting?
- What is the importance of troubleshooting in Wire Saw machine Operation?

Say

There are various factors that affect the speed and life of diamond segmented wire saw. Some of these include:

3.4.1.1: Uncontrollable Factors

Explain

1. Rock types or the presence of quartz in the rock
2. Type of cut (vertical, level, perpendicular) the machine is used for
3. Size of the cut.

3.4.1.2: Controllable Factors

Explain

1. **The setting of the machine:**
 - The line of the railing and the line of the level hole being equidistant.
 - Flywheel being aligned with the hole.
2. **The wire setting:**
 - The upper and lower wire being in a plumb line.
 - Keeping the pulley above the surface of the cut.
3. **Forward force:**
 - The wrong forward force causes wear and tear of the beads and is one of the main reasons for affecting the performance of the wire.
4. **Cutting:**
 - If the cutting speed is too high, then the diamond segment beads may get polished and if the cutting speed is too low, then the diamonds may fall out.
 - When the cut is nearing the end, the wire advances on smaller diameter and the diamond beads are rotating at a high speed. This causes high wear and tear. It is essential to run the machine at a low speed as the cut is ending.
5. **Watering:**
 - Too much water will cause the segment to be polished. This causes difficulty while cutting.
 - Too little water causes the diamond segment beads to be worn out faster machine at a low speed as the cut is ending.
6. **Operator's technical knowhow and sense of responsibility:**
 - The operator must always keep in mind that the diamond segmented wire is an expensive tool and extreme care is needed for maximum production.

3.4.2: Importance of Guide Pulley

Elaborate

The guide pulley is an important part of the wire saw machine, and hence the operator is required to know its function and how it can be used optimally.

3.4.2.1: Advantage of Guide Pulley

Elaborate

- If the diamond segmented wire is gripped strongly on the pulley, it lasts longer, does not break often. From a safety point of view too, this is a good thing.

If the diamond segmented wire runs on a pulley, the beads and other parts have an even or uniform wear and tear and also extend its life.

- With the help of the guide pulley, the diamond segmented wire runs without getting entangled, and it provides a good cut. Also electricity costs are reduced.
- As the wire moves around the pulley, the load on the pulley is uniform which reduces the cracks and thus extends its useful life.
- Since the wire tends to jump less often and works in a proper manner, this extends the life of the rubber ring and reduces its cost
- The wire saw can be kept at a distance from the cut ensuring that there is correct tension in the diamond wire. This also makes it safer.
- Less cooling water needs to be used.

3.4.2.2: Disadvantage of Guide Pulley

Elaborate



- It takes additional time for the setting of the machine and guide pulley.
- Additional money is needed to be spent for the guide pulley and stand.

3.4.3: Key Issues with Wire Saw Panel

Say



The main problems in the wire saw are seen in the contacts, as has been explained below.

3.4.3.1: The Contacts Generate Noise

Explain



Solution: The connection must always be checked and they must be tightened often so that the noise is not caused.

3.4.3.2: Control Circuit Connections are Faulty

Explain



Solution: The contacts should be kept clean in a timely fashion.

3.4.3.3: Loose Connections in the Control Circuit

Explain

Solution: The connection must always be checked and they must be tightened often so that the noise is not caused

3.4.3.4: Contacts Gets Excessively Heated

Explain

If the voltage applied to contacts is low, then their magnetic grip is reduced.

Solution: The voltage should be stable, for which the voltage set up should be maintained.

3.4.3.5: Excess Electricity Flowing beyond Normal Limits

Explain

Solution: In such situations contacts which are big in size should be used.

3.4.3.6: Damage Done by Short Circuit

Explain

Solution: Locate the fault and resolve it and also check if the fuse rating is correct or not

3.4.3.7: The Contact does not Drop once it is connected

Explain

1. This can happen due to the voltage being unchanged

Solution: For this it is essential to check the wiring in the coil circuit. In case there is a fault in the wiring, the voltage does not fluctuate.

2. If the magnet is damaged or rusted parts become stuck permanently

Solution: It is essential to check such parts from time to time and to change them if necessary. wiring, the voltage does not fluctuate.

3.4.3.8: The Coil is getting Excessive Hot

Explain

Solution: Check the voltage being applied at the terminal. Replace the coil with a high voltage rating.

3.4.3.9: Bimetal Overload Tripping

Explain



1. If the bimetal setting is wrong, then this causes continuous tripping.
Solution: Set the relay correctly.
2. This can happen due to excessive overload.
Solution: Check for the probable causes for the motor to draw excess current.
3. When the supply voltage is reduced.
Solution: Do not start the motor until the voltage problem is solved.

3.4.3.10: The Motor is burnt as it did not trip properly

Explain



1. The bimetal relay settings are wrong.
Solution: Check the relay setting and change the relay setting.
2. Dust or rust etc causes mechanical faults.
Solution: For this the relay should be thoroughly cleaned and changed if necessary.
3. Contacts are sticking due to faulty control wiring.
Solution: check the circuit.

3.4.3.11: The Fuse in Panel Blows

Explain



1. Due to short circuit the fuse blows constantly
Solution: Check the circuit using a megger.
2. The fuse rating is very low
Solution: Choose the fuse according to the correct rating of the panel and use the right fuse.

3.4.3.12: The Fuse does not Blow even in event of a Short Circuit

Explain



1. The rating of the fuse is very high
Solution: Please use only fuses with the correct rating.

3.4.4: Common Problems and Solutions

Demonstrate

Following are some common problems while operating a wire saw machine, along with their solutions.

S. No.	Problem	Reason	Solution
1	The Diamond segment is getting worn out in a conical shape. (Diamond segment is cutting extra material)	1. Back speed is more than necessary, while cutting is good. 2. Cutting is being done in the direction opposite to the direction indicated on the wire saw. 3. Wire is not correct and diamond segment per meter are less 4. Cutting Speed is less but more cutting is being done.	1. Reduce the back speed. 2. Reverse the direction if you come to know early. Reduce the back speed and complete the cut if you come to know late. 3. Change the wire if you come to know early. Keep the number of segments per meter appropriate. 4. Increase cutting speed and reduce back speed.
2	Wire is being worn out in helical shape (wire is not rotating correctly in the cut)	1. Back speed is more as compared to cutting capacity. 2. Wire is not pre-loaded correctly.	1. Reduce the back speed. 2. Load the wire correctly.
3	Wire is being worn out in a flat of eccentric shape (Wire is not rotating correctly in the cut)	There is less or no load on the wire.	Rejoin the wire with the correct load.
4	the Plane of the cut is not correct. (Wire is not moving correctly)	The Wire Saw fly wheel and the hole are not lined up correctly.	Line up the wire saw flywheel and the hole correctly.
5	Wire is heating up. (Cooling is not correct)	Water supply is not appropriate or not enough.	Check the water supply and flow of the water.
6	Wire is oscillating helically.	Cut speed is more than needed.	Reduce the speed until the oscillation stops.
7	Wire is getting disentangled. (Wire is vibrating on the flywheel)	The Rubber lining of the flywheel has been damaged. The balance of the fly wheel is not correct. The alignment of the flywheel and guide pulley is not correct.	Replace the rubber lining of the fly wheel. Check the bearing of the flywheel and change if needed. Correct the alignment of the flywheel with the guide pulley.

S. No.	Problem	Reason	Solution
8	Once the machine is stopped, there is difficulty in starting the wire (There is increased tension before the wire stops)	The interruption process of cutting has not been implemented.	Operate the machine in forward direction, reduce the tension in wire, then start again.

3.4.5: Other Problems and Solutions

Say

There are various other problems such as water problems, problems with panel, level on agreement, etc.

3.4.5.1: Water Problems

Explain

If the wire is decayed or goes over mud by cutting it, then the cut gets filled with mud and the wire becomes dry. In such a case, a wire or iron bar should be inserted into the cut and cleaned.

3.4.5.2: Problems With Panel

Explain

If the motor keeps shutting down again and again or starts tripping, then you should realize that there is low voltage or there is a problem in the panel. Thus that should be rectified and then the machine should be operated.

3.4.5.3: Level or Alignment

Explain

If the machine has been set properly before operating, and yet if the machine starts moving, then the level should be checked and appropriate packing should be applied. If the machine has been set on mud, then as soon as the water of the cut reaches the mud, the level will be damaged and alignment will also be displaced.

3.4.5.4: Wire Entangling or Breaking

Explain

When the diamond wire is being locked, the sleeve should be pressed properly so that the wire does not break. If the wire gets entangled, then it is better to remove it with the help of water because if the wire breaks inside, then the entire cut has to be made from the start.



Fig. 3.3.5. Using a wire saw machine without wire tangling

Activity-1

- Conduct a 'Resolving controllable factors during wire saw operation Activity'.
- Ask the students to make group of 5 students.
- Students have to do a demonstration on Resolving controllable factors during wire saw operation Activity.
- One group of Students will have 60 minutes for preparing for demonstration. 60 minutes for demonstration.
- Appreciate learning skill of students and tell correct Activity, if any Activity is wrongly demonstrated.

Activity	Time	Resources
Resolving controllable factors during wire saw operation Activity	2 Hours	Participant Handbook, Notebook, pen, Flipchart / Laptop, Wire Saw Machine, Safety Equipment, Marble Quarry

Activity-2

- Conduct a 'Resolving day to day issues related to wire saw machine Activity'.
- Ask the students to make group of 5 students.
- Students have to do a demonstration on Resolving day to day issues related to wire saw machine Activity.
- One group of Students will have 60 minutes for preparing for demonstration. 60 minutes for demonstration.
- Appreciate learning skill of students and tell correct Activity, if any Activity is wrongly demonstrated.

Activity	Time	Resources
Resolving day to day issues related to wire saw machine Activity	2 Hours	Participant Handbook, Notebook, pen, Flipchart / Laptop, Wire Saw Machine, Marble Quarry

UNIT 3.5: Enhancing Productivity

Unit Objectives

At the end of this unit, students will be able to:

1. Understand the importance of productivity
2. Identify cycles and calculate cycle time
3. Identify factors affecting productivity cycle
4. Identify factors affecting efficiency

Resources to be Used

- Laptop
- Projector
- White Board
- Marker
- Duster
- Details and Photos of Wire Saw Machine Parts
- Wire Saw Machine
- Field visit to Marble mine

Do

- Greet the participants for the day.
- Give Summary of previous Session.
- Ask for any doubts in previous Session.
- Acknowledge for their doubt-raising, if any. Clear the doubts.
- Give details of today's session and what they are going to learn.
- Encourage them to share their thoughts and doubts now and during process of this course.

3.5.1: Importance of Productivity

Ask

- What is Productivity?
- What is the importance of Productivity in Wire Saw Operation?

Explain

A wire saw machine and diamond beads are used to cut marble in marble mines. Diamond beads are important when it comes to number and cost.

In order to use the wire saw efficiently, these should be used carefully. They should be used in every shift in such a way that maximum cutting can take place, because marble cutting is largely dependent on these wires and ultimately the operation of the wire saw is dependent on these too. The order of operation and work area should be planned such that minimum time is wasted in the operation, and it can be used to its maximum capacity.

3.5.2: Cycle and Cycle Time

Explain

A wire saw performs some basic functions such as rotating the diamond segmented wire in order to cut marble. The AC/DC motor attached to it helps in forward and backward movement.

The diamond segmented wire actually cuts the marble.

The electricity panel also plays an important part in the Wire Saw operation. Similarly a crane equipped truck is also important in moving the wire saw machine from one place to another.

The drill makes horizontal and vertical holes for wire saw operation. The diamond wire is threaded through these holes and the marble is cut.

One complete rotation of the basic function (besides drilling) of the wire saw is called a cycle.

The amount of time taken to complete a cycle is called the cycle time.

There are three periods in a cycle time.

1. First period is time interval which is needed to do actual work (shifting, making the wire etc).
2. Second period is the amount of time needed to put the wire Saw in place for doing any work.
3. Third period is the delay due to resolving the issues in getting the Wire Saw in place.

Sometimes extra time is needed due to face condition (cracks etc). The total number of cycles executed in each shift affects the production rate.

The production rate (cutting) is dependent upon rock condition, capacity of wire saw machine and condition of diamond segmented wire.

3.5.3: Factors Affecting Productivity

Explain

Any productivity cycle of a Wire Saw can be divided into 6 parts. These parts are shown in the following figure:



Fig. 3.5.1. Productivity cycle

Every part is responsible for some part of the total cycle time. Every part is dependent upon different factors.

3.5.4: Factors Affecting Efficiency

Explain

The number of minutes the Wire Saw machine works in an hour is its efficiency. The classification of the efficiency is as follows:

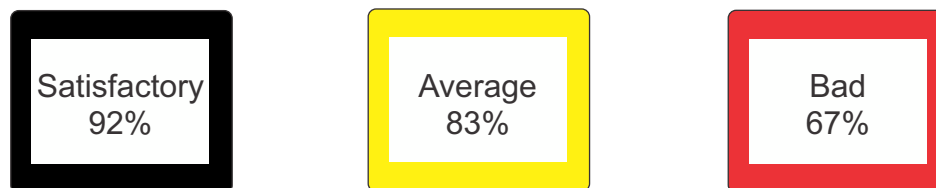

The work time depends on all the cycle factors listed above. Other than this, the work time is reduced in case of working at night, blasting, weather, face condition and power shut down.

Inexperienced operators, less skills in supervision and management are also responsible for reducing the amount of work done.

Work conditions affect the efficiency of the equipment. Following things determine the work conditions:

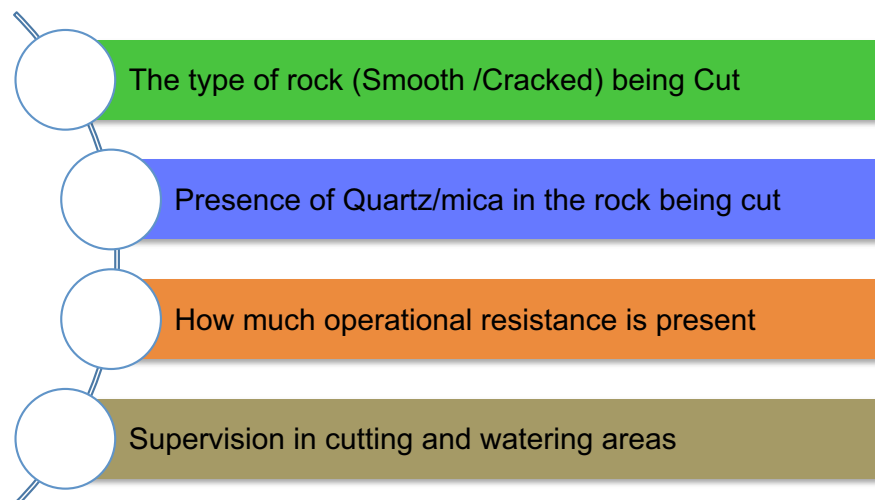

Fig. 3.5.2. Determining work condition

3.5.5: Factors Affecting Productivity Cycle

Explain

The work execution is the capacity of the wire saw to neutralize the limiting factors in its execution and provide power at a steady rate.

Following factors are included in this:

- The main motor which rotates the fly wheel.
- The AC/DC motor which moves the Wire Saw backward and forward.
- Diamond segmented wire which does the job of cutting.
- Availability of electricity and water.

The following factors limit the execution of wire saw in mines:

- The nature of the rock being cut.
- The condition of the diamond segmented wire.
- The lack of availability of water for cooling the diamond segmented wire and cleaning the cut.

The cutting speed of the wire saw is limited by the rock condition. The harder the rock, lesser is the amount of cutting. This cutting speed can be about 60-80 square feet/hour.

The diamond segmented wire does the work of rock cutting. If the beads on it get worn out, then the speed of the cutting is affected.

If enough water is not available, then the Wire Saw operation is affected.

3.5.6: Wire Saw Production

Explain

The production (cutting) cycle of the Wire Saw is divided into five parts. The following figure shows the five parts of production cycle of a wire saw machine:

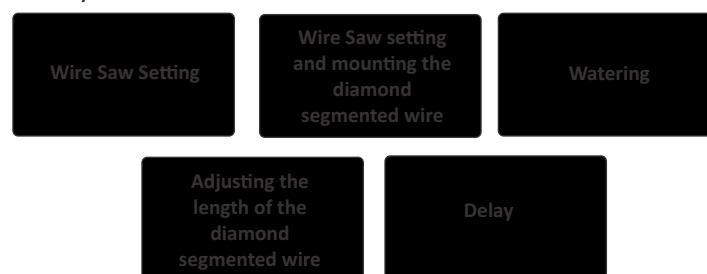

Fig. 3.5.3. Production cycle of a wire saw machine

Cycle time is the total time needed to perform one cut including all these parts. In order to achieve maximum production, the operator should complete the first four parts on time and the fifth should be as minimized as possible. This can be done by appropriately managing the capacity of the Wire Saw and other parts.

3.5.7: Things to Remember about Productivity

Explain

Following are some factors to be kept in mind for enhancing the productivity:

- Choose a wire saw with appropriate capacity as per the work at hand.
- Procure and crimp the diamond segmented wire in the appropriate way.
- Set the wire saw machine correctly.
- Make adequate arrangements for water pump, foot valve and water.
- Do not be careless about preventive maintenance of the Wire Saw so that machine can be used for a long time.
- Make proper arrangements for the electric panel cable.
- Keep appropriate tension in the diamond wire during rock cutting.

Activity-1

- Conduct a 'Wire Saw Productivity Improvement Activity'.
- Ask the students to make group of 5 students.
- Students have to do a demonstration on Wire Saw Productivity Improvement Activity.
- One group of Students will have 60 minutes for preparing for demonstration. 60 minutes for demonstration.
- Appreciate learning skill of students and tell correct Activity, if any Activity is wrongly demonstrated.

Activity	Time	Resources
Wire Saw Productivity Improvement Activity	2 Hours	Participant Handbook, Notebook, pen, Flipchart / Laptop, Wire Saw Machine, Marble Quarry

UNIT 3.6: Ensuring Safety

Unit Objectives

At the end of this unit, students will be able to:

1. Identify factors to be kept in mind for wire saw operation safety
2. Identify various mining safety equipment

Resources to be Used

- Laptop
- Projector
- White Board
- Marker
- Duster
- Details and Photos of Wire Saw Machine Parts
- Wire Saw Machine
- Field visit to Marble mine

Do

- Greet the participants for the day.
- Give Summary of previous Session.
- Ask for any doubts in previous Session.
- Acknowledge for their doubt-raising, if any. Clear the doubts.
- Give details of today's session and what they are going to learn.
- Encourage them to share their thoughts and doubts now and during process of this course.

3.6.1: Wire Saw Operation Safety

Ask

- What are the safety points in Wire Saw Operation?
- Why Safety is important during Wire Saw Operation?

Explain

Safety is a primary concern for all mining organisations, employers and employees. Detailed precautions should be taken to ensure a safe workplace. The officers and supervisors should routinely inspect the work conditions. The employers should ensure improving on the safety programs and training to necessary employees.

Being alert and applying common sense is of prime importance in mines. Also important is understanding when to raise alert and report malfunctioning or unsafe conditions to higher authorities who can take action. You should take safety concerns extremely seriously to avoid issues that can be avoided with precautions as shown in the following figure:

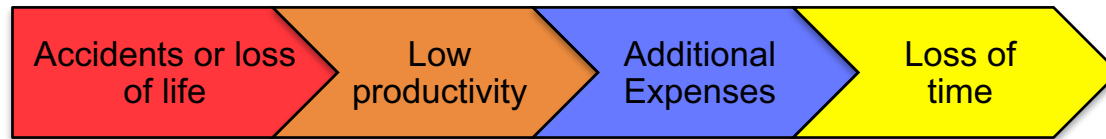

Fig. 3.6.1. Issues that can be avoided with precautions

3.6.1.1: Specific Safety Rules and Guidelines

Explain



It is the responsibility of every employee to follow prescribed safety rules.

Following are some key safety rules and guidelines for wire saw operators:

- Adhere to the work safety processes defined for any special work.
- In case of illness or if you get hurt, however minor the injury, report it immediately to your supervisor.
- No employee should in any circumstances self-examine his own or others injury. For example, if something enters your eye, do not try to remove it yourself.
- If your leg, back or neck is fractured, or if someone is unconscious due to an accident, or if there is serious injury to the head, then the person should be moved only with the help of First Aid trained employee.
- Set up pulleys and power units in proper alignment with the cut.
- Barricade areas near the drive wheel, pulleys and exposed moving wire sections to prevent access by workers and prevent injuries.
- Ensure workers should be limited access to twice the length of the longest piece of wire, meaning if the longest piece of wire is 10 feet, the worker should not come within 20 feet of the wire saw.
- When joining two ends of the diamond cable, it is the wire saw operator's responsibility to ensure that the crimps are placed on the diamond cable properly and are pressed to the maximum pressure suggested by the wire manufacturer.
- Do not wear loose or ill-fitting clothes or jewellery near the machine. They can be entangled in fast moving machines and serious injury can occur.
- Do not disturb of any other employee. If you do this, he could get hurt. If it is necessary to get the attention of a specific employee when it is safe.
- Always use your safety equipment such as goggles, safety glasses, masks, gloves, helmet etc.
- Keep equipment, skids, bins, boxes and other objects in such a way that they do not obstruct exits, fire-fighting equipment etc. Doors and paths in between seats used for escaping a fire should always be kept free from obstruction.
- Keep the workplace clean and tidy.

- Use compressed air only for the purpose it is intended. Do not clean your clothes with it and do not play with it.
- Do not smoke in your workplace.
- Turn off the machine before cleaning, repairing or going close to it.
- Do not operate at a speed which is more than the safe speed for the given conditions.
- Do not obstruct any fire-fighting equipment.
- Do not operate machines and equipment unless specifically told to do so by your supervisor.
- When going moving around in a workplace use pre-specified paths, never use dangerous short cuts.
- Report any unsafe situation or activity to your supervisor.
- Lift load in an appropriate manner – use your legs, not your back to lift very heavy weight. Share load or take help from others.
- Do not adjust, clean or oil a machine in a working state.
- If any liquid like oil or grease falls on the floor, clean it immediately. Put trash and papers in appropriate containers; do not throw them here and there.
- Wear safety shoes and appropriate clothes.

3.6.1.2: Safety Inspection Check List

Explain



It is the responsibility of every employee to be aware of potential dangers. If you come to know of any situation or other probably dangers related to the following list, report it immediately to your supervisor.

- Slippery floor and pedestrian paths.
- Things like hose, links, piping etc against which one can stumble.
- Lack of signs or lights (or not in working condition) near entry or exit points.
- Loose or broken stairs.
- Objects or equipment kept in a dangerous manner.
- Open or broken windows.
- Open doors or gates.
- Dripping steam, water, oil etc.
- Obstructed pathways between seats.
- Obstructed fire-fighting equipment, hose sprinkler etc.
- Obstructed fire exits.
- Any equipment heating up while operation or heating up more than necessary.

- Rags soaked in oil.
- Smoking in non-smoking areas.
- Leaking ceiling.
- The signs indicating change of direction or warnings not being in place.
- Safety equipment not working in a proper way.

3.6.2: Safety in Marble Mines

Explain

Following are some key considerations while working in marble mines.

- You should know the safety program of your mine.
- You should be appropriately dressed. Helmet, gumboot etc are for your safety.
- It is necessary that you have all the information about your workplace and surrounding areas, for eg. if there is a crack.
- You should have practical information about the rules and signs for transportation in the mine.
- You should be ready to face any emergency situation with courage.
- You should information about first aid and methods to put out fires.
- You should be vigilant about your own and your colleague's safety.
- You should use safety equipment for protection from electric dangers.

3.6.2.1: Causes of Accidents

Explain

Following are some key causes of accidents in marble mines.

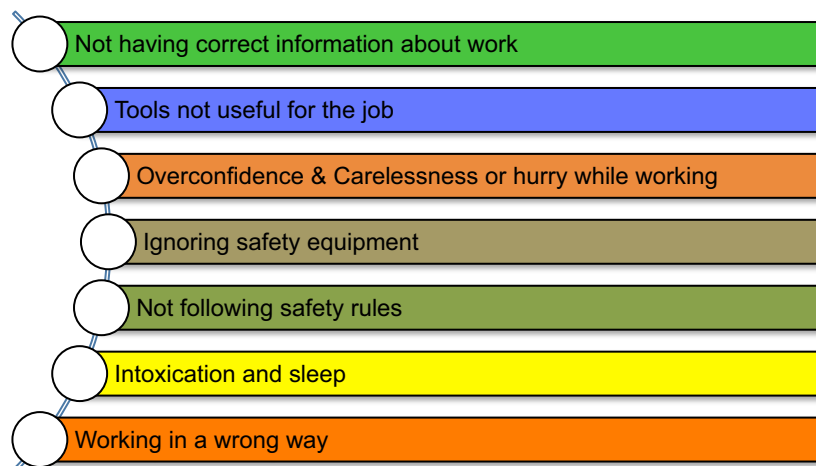

Fig. 3.6.2. Causes of accidents

3.6.2.2: Safety Do's

Demonstrate

Always do the following to ensure safety:

- Follow the safety rules completely and be disciplined.
- Follow the directions given by your supervisor
- Carefully follow the rules to be observed during blasting
- Always use safety equipment such as safety helmet, safety shoes and others.
- If your colleague is making any mistake, point it out to him.
- Before starting work, search your work place with respect to safety rules, and only then begin your work.
- Do every task carefully after giving it focused thought.
- Be present at your workplace in the uniform supplied by your company.
- Participate in mine safety programs, and encourage your colleagues to do so too.

3.6.2.3: Safety Don'ts

Demonstrate

Never do the following:

- Never enter a mine without authorization
- Do not encourage your co-labourers to work in dangerous places.
- Do not enter places that have been fenced or declared unsafe.
- Do not come to duty wearing loose clothes.
- Do not quarrel with your coworkers.
- Do not sleep at your workplace, and do not litter the workplace.
- Do not be careless even with small injuries
- Do not do anything that may endanger the life of co-workers

3.6.2.4: Other Key Considerations

Explain



- Every operator should register his attendance in the office before coming to duty.
- Every operator should be careful and attentive on duty.
- .No operator should sit or walk near a vertical face in a mine. You should keep a distance
- from the face while walking so that any loose face or stones do not fall on you.
- No operator should cross any type of fencing in the mine.
- No operator should walk on the edge of the bench or let his co-workers walk there.
- No operator should do any unauthorized work.
- No operator other than authorized ones should go near the place where blasting is taking place.
- Once the blasting siren is sounded, every person should take appropriate shelter and come out only after the all clear siren is sounded after blasting is complete.
- No operator should stand on the foot board of a moving dumper or loader.

3.6.2.5: Mine Safety Equipment

Demonstrate



Make a note of the following regarding safety equipment.

- Your supervisor should make sure that you receive safety clothes and equipment necessary.
- Use them according to directions and take good care of them. If these are lost or damaged due to your carelessness, you may be asked to pay the cost.
- The company will determine whether safety shoes are necessary for specific work or work areas. Under no condition will any worker be allowed to work in slippers or open toed shoes.
- Employees are directed to wear safety goggles. If this policy is strictly followed, then incidences of eye injuries are greatly reduced.
- All employees driving any vehicles should always use seat belts. The driver is responsible for making sure that all the passengers are wearing their seat belts.
- Keep your work place clean and tidy. Keep all machines and other objects away from grease or oil, in order to prevent slipping and falling promptly clean any liquids from the floor.
- Put trash in appropriate cans.

The following figures shows the various mine safety equipment:



Fig. 3.6.3. Various mine safety equipment

Activity-1

- Conduct a 'Safety checks during Wire Saw operation Activity'.
- Ask the students to make group of 5 students.
- Students have to do a demonstration on Safety checks during Wire Saw operation Activity.
- One group of Students will have 60 minutes for preparing for demonstration. 30 minutes for demonstration.
- Appreciate learning skill of students and tell correct Activity, if any Activity is wrongly demonstrated.

Activity	Time	Resources
Safety checks during Wire Saw operation Activity	4 Hours	Participant Handbook, Notebook, pen, Flipchart / Laptop, Wire Saw Machine, Marble Quarry

Activity-2

- Conduct a 'Mine Safety Equipment Demonstration Activity'.
- Ask the students to make group of 5 students.
- Students have to do a demonstration on Mine Safety Equipment Demonstration Activity.
- One group of Students will have 60 minutes for preparing for demonstration. 30 minutes for demonstration.
- Appreciate learning skill of students and tell correct Activity, if any Activity is wrongly demonstrated.

Activity	Time	Resources
Mine Safety Equipment Demonstration Activity	2 Hours	Participant Handbook, Notebook, pen, Flipchart / Laptop, Mine Safety Equipment

Notes



Skil India
कौशल भारत - कुशल भारत



4. Carrying Out Reporting & Logging - Wire Saw Operator

Unit 4.1 - Documenting Daily Activities

Unit 4.2 - Organisational Guidelines and Reporting Procedures

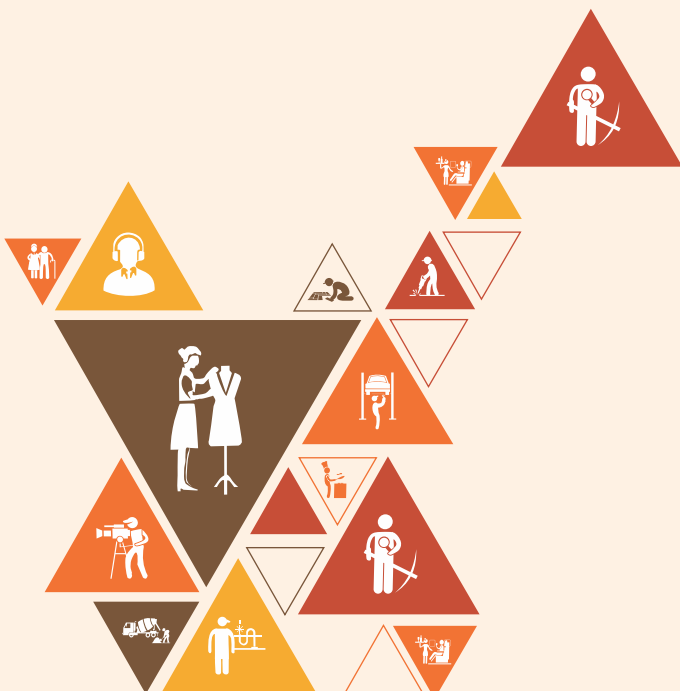

MIN/N0211

Key Learning Outcomes

At the end of this module, students will be able to:

1. Understand the importance of reporting
2. Understand how to fill a job card
3. Understand importance of reporting structures and organizational policies and guidelines

UNIT 4.1: Documenting Daily Activities

Unit Objectives

At the end of this unit, students will be able to:

1. Understand the importance of documentation
2. Fill your daily job card

Resources to be Used

- Laptop
- Projector
- White Board
- Marker
- Duster
- Wire Saw Machine
- Field visit to Marble mine

Do

- Greet the participants for the day.
- Give Summary of previous Session.
- Ask for any doubts in previous Session.
- Acknowledge for their doubt-raising, if any. Clear the doubts.
- Give details of today's session and what they are going to learn.
- Encourage them to share their thoughts and doubts now and during process of this course.

4.1.1: Importance of Documentation

Ask

- What is Documentation?
- Why documentation is required?

Say

Machines can be complex and cost a lot of money. When a machine breaks down, every second can lead to loss of production which can affect schedule, or more importantly, accidents and loss of life.

Mining machine operators, such as a wire saw operators, control machines that cut or move materials. They can cause potential risk to life and property if not handled with care.

Machine operations, like other employees in a mine need to be:

- Precise
- Careful
- Disciplines to do their work well.

Working in mines also involves a lot of hazard and threat to life. This is why it is important to be precise and maintain detailed records of operations conducted daily.

Most mining organisations may have a recording system where each employee records the following:

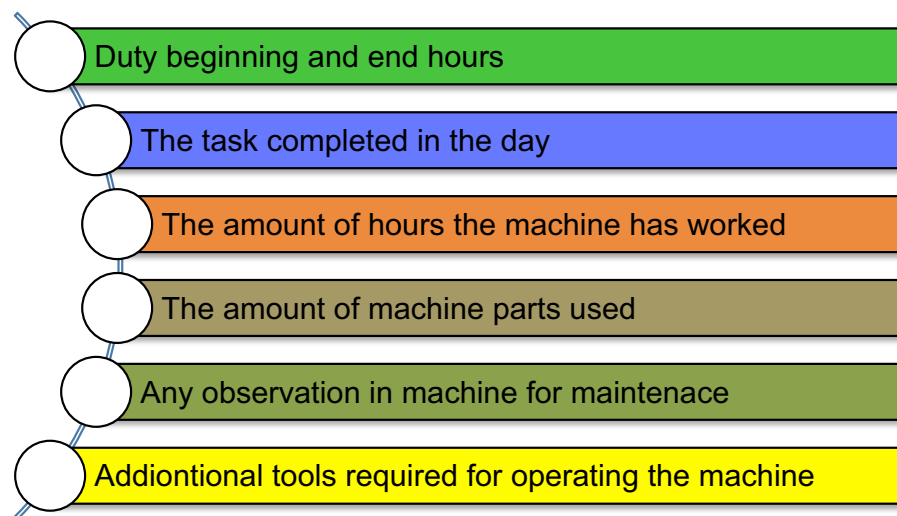

Fig. 4.1.1. Systems for employees records

This information must be updated and passed on to a supervisor for follow up on a daily basis. Communication with your supervisor is important for a wire saw operator, as well as for any heavy machinery operator. In case there is a problem with a machine you may need expert technician advice to ensure if it is ok to continue, or it may be that you have to stop to avoid further damage.

For routine repairs and maintenance you will need to pre-plan to determine the most suitable time for the machine to be off use for check. You may need to obtain a replacement machine or rearrange work activities. The following figure shows a person performing safety checks:



Fig. 4.1.2. Performing safety checks and precautions is a must

4.1.1.1: Following Instructions According to Requirements

Explain

Every task or assignment has its own requirements. These requirements are conveyed by the supervisor to individual employee or a team of workers while assigning the task. The success of any assignment is measured on the basis of how the requirements are fulfilled. If the requirements are not met, the task is considered to be incomplete. Therefore, before starting a new task, establish and agree on requirements with appropriate people. Some of the common reasons of not fulfilling requirements are shown in following figure:

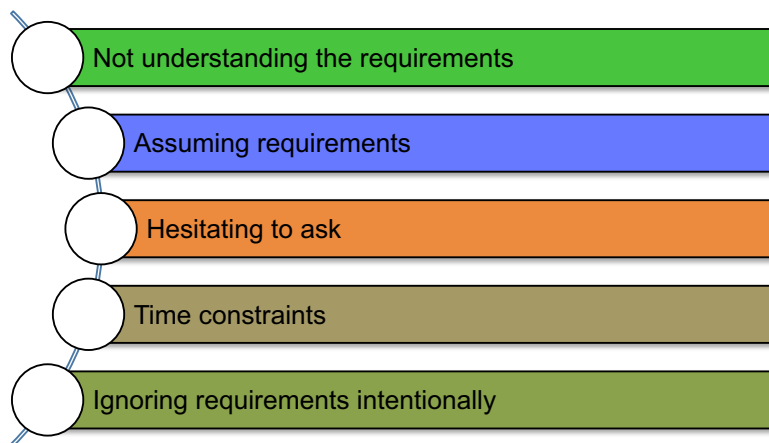

Fig. 4.1.3. Common reasons for not fulfilling records

There are some guidelines you can follow to ensure that you understand the requirement well before you begin your task. These are shown as the following figure:

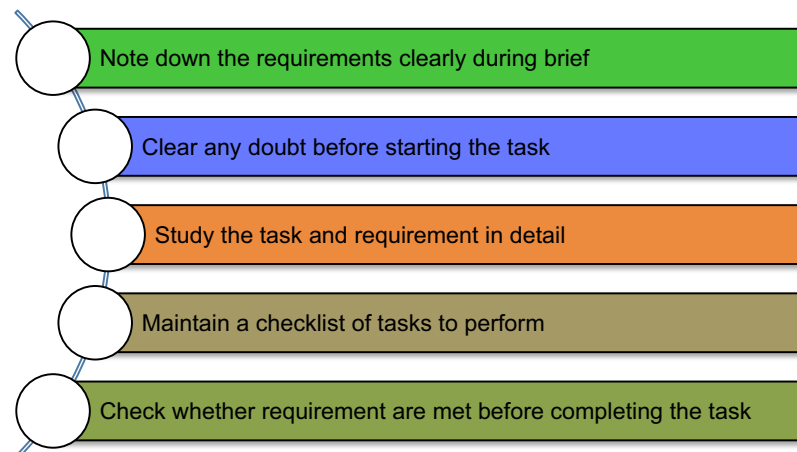

Fig. 4.1.4. Guidelines to understand requirement

4.1.1.2: Daily Job Card

Demonstrate

A daily job card is mandatorily to be filled by the wire saw operator. This includes details of:

- The name of the operator
- The working hours of the operator – shift beginning and end time
- The total number of work hours.

- The name and number of the machine with the date
- The work place and contract number
- The type and size of the cuts
- The number of the diamond wire used
- The number and readings of the electric panel attached to the machine at the beginning or the operations as well as at the end
- The time at which the machine started
- Remarks about the work, if any.
- The time for which the machine was not working due to the machine breakdown, if any, adding list of reasons
- The total breakdown time.
- The safety equipment on the machine.
- The details and time for the lock, beads of the diamond wire.
- Details of lost beads, if any.
- The cutting speed achieved
- The condition of the face where the Wire Saw has been used
- In case the Wire Saw operator wishes to give specific instructions about machine or work place to the person in the next shift
- A record of any accidents/near misses during work

In the end, the Wire Saw operator and shift supervisor should sign on the job card.

Following is an example of a job card.

Job Card - Wire Saw Operator						
S. No.			Date			
Control No.			Type of Cut			
Machine Panel No.			Wire No.			
Date	Start	Stop	Total Hours		Remarks	Operator
			Run	B. D.		

Total Saving Time		Bit Loss		Cut Size		
Total B/D Time		Speed		Sign of Dept. Head		

Fig. 4.1.5. Job card - wire saw operator

Tips 

Ensure all documentation and logging of reports is done on the scheduled time. Delaying records or delay in alerting authorities may result in serious losses or oversight.

Demonstrate 

Following is an example of a log of malfunctioning or breakdown.

Date	Wire No.	Lock	Bits Issued	Bits Received	Bits Balance	Time	Supervisor
Break down Details							
S. No.	Breakdown Reason						Total Time
1	Wire Cutting						
2	Wire Breaking						
3	Wire Making						
4	Shortage of Water						

5	Blasting		
6	Machine & Pulley Setting		
7	Cont. Site Work		
8	Machine Break down		
9	Cable Fault (Electrical)		
10	Motor Fault (DC/AC)		
11	Panel Fault		
12	Other Electrical Fault		
13	Power Cut		
14	Machine Shifting		
15	CPF (Channel Pulley Fault)		
16	Others		
	Total		

Fig. 4.1.6. Break down slip

Activity-1

- Conduct a 'Filling Daily Job Card Activity'.
- Ask the students to make group of 5 students.
- Students have to do a demonstration on Filling Daily Job Card Activity.
- One group of Students will have 60 minutes for preparing for demonstration. 30 minutes for demonstration.
- Appreciate learning skill of students and tell correct Activity, if any Activity is wrongly demonstrated.

Activity	Time	Resources
Filling Daily Job Card Activity	2 Hours	Participant Handbook, Notebook, pen, Flipchart / Laptop, Blank format of Daily Job Card, Filled job card example

UNIT 4.2: Organisational Guidelines and Reporting Procedures

Unit Objectives

At the end of this unit, students will be able to:

1. Understand the importance of work policies and guidelines
2. Work within the limits of your authority

Resources to be Used

- Laptop
- Projector
- White Board
- Marker
- Duster
- Field visit to Marble mine
- Marble mine Organisational Procedure copy
- Marble mine Organisation Structure

Do

- Greet the participants for the day.
- Give Summary of previous Session.
- Ask for any doubts in previous Session.
- Acknowledge for their doubt-raising, if any. Clear the doubts.
- Give details of today's session and what they are going to learn.
- Encourage them to share their thoughts and doubts now and during process of this course.

4.2.1: Work Policies and Guidelines

Ask

- What is Work Policies and Guidelines?
- Why we need to follow these guidelines?

Say

Every kind of work and every organisation has its own rules and policies. These rules and policies must be adhered to by the employees working in the workplace.

An organisation usually formulates or adopts various policies and procedures to assist in defining and determining all its major decisions and actions.

4.2.2: Policies and Guidelines

Explain

Every kind of work and every organisation has its own rules and policies. These rules and policies must be adhered to by the employees working in the workplace.

An organisation usually formulates or adopts various policies and procedures to assist in defining and determining all its major decisions and actions.



Fig. 4.2.1. Organisation policies handbook

Make sure you take a look at the handbook thoroughly before within the first few days of joining the job. You can request for the handbook to your supervisor

Some typical the company guidelines include:

- Employee code of conduct (for example, dress code and behavioral approach)
- Attendance policy (for example, time of entry into and exit from the workplace)
- Leave policy (for example, different types of leaves)
- Workplace safety (for example, understanding and following fire safety guidelines)
- Harassment policy (for example, engaging in a course of unwelcoming comment or conduct against a worker in a workplace)
- Substance abuse policy (for example, ban of smoking, alcohol, and drugs)
- Property abuse policy (for example, damaging company assets)



Fig. 4.2.2. Workplace safety manual and evacuation plan

4.2.2.1: Procedures

Explain



A procedure is step-by-step instructions for implementing an organisation's policies or tasks in day today operations. Procedures and policies help an organisation to:

- Provide a framework for actions that help employees quickly understand what is expected of them
- Stop employees from discussing and re-discussing the same issues every time they arise
- Help in legal matters
- Act as a tool to improve the quality
- Create goodwill and trust among employers, customers and clients
- Help employees behave in a professional and responsible manner

4.2.2.2: Organisational Standard

Explain



Standards define minimum requirements to be maintained to ensure compliance with any policy. Organisational standards specify minimum performance levels, describe best practices within the organisation, or serve as the list of parameters that the organization and its employees must follow. They are also helpful in verifying compliance of policy during audits and assessments.

A standard can be:

1. An object or measure of comparison that defines or represents the magnitude of a unit.
2. A characterisation that establishes allowable tolerances or constraints for categories of items and parameter settings.
3. A degree or level of required excellence or attainment

Examples of organisational policies and standards can be related to:

- Working ethically as per values of the organisation
- Common understanding of services
- Regulatory and statutory compliance
- Performance and productivity
- Standards for quality of services
- Guidelines for reduction of errors, safety and security

It is the organisation's responsibility to ensure the employees know and understand the guidelines and policies. It is the employees' responsibility to adhere to the guidelines and policies.

Not conforming to organisational guidelines and policies may lead to destruction of trust and goodwill and even loss of a job.

4.2.3: Working with Limit of Authority

Explain



Working within an organisation involves working with and inter-dependency among various teams. This also involves working with multiple co-workers, stakeholders and people at various levels within the organisation.

An organisation is divided into hierarchies, departments, divisions and teams to make best use of resources and capacity available within the company, and provide services accordingly.

4.2.3.1: Understanding Authority Levels and Organisational Structure

Elaborate



It is important to be clear about what the limits of your authority are, which issues need to be escalated, and which need to be resolved at your level.

It is also important to involve, seek guidance or support and assistance from those who are designated in the organisation at various authority or decision-making level.

You should always respect the levels of authority in the organisation, the expertise and guidance people at a higher authority level can provide, and update them about the progress or issues at work regularly.

Following figure shows the advantages to maintain authority level and hierarchy:



Fig. 4.2.3. Advantages of maintaining hierarchy level

A reporting structure is simply a framework designed to divide, organize, and coordinate the different activities of an organisation. We can consider reporting structure as some form of a hierarchy in which groups of people have been asked to coordinate with each other through some ground rules to accomplish organisational goals and objectives as shown in following figure:

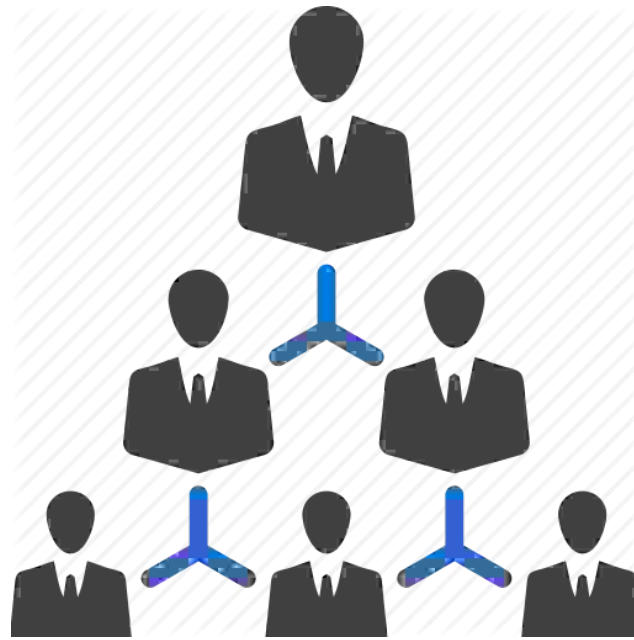

Fig. 4.2.4. Hierarchy in an organisation

4.2.3.2: Documents needing Counter Signature of Supervisor

Elaborate



In your day-to-day work, a few documents always require counter-signature from your supervisor. These include:

- Surveyor's book, listing all plans/ sections/ tracings/ surveyors instruments, field books and other notes
- Certificates on every plan/ section prepared by or prepared under the supervision of a surveyor
- Records of results of inspections of working, both present and disused, beneath and within 45 m of:
 - Rivers, jores, etc
 - Roads, railways
 - Dwellings and other structures
 - Records of fortnightly tests of the machine and related equipment and vehicles
- Record of written permission given by manager to persons lighting fire in an o/c mine or within 15 m from any entrance to a mine
- Result of analysis of dust samples
- Record of examination of protective measures, whether in use or not
- Record of first inspection of a mine or part which is reopened
- Record of occurrence of noxious or inflammable gas in a mine or part
- Manpower distribution plan

4.2.3.3: Keeping Authorities Informed and Seeking Help

Explain

You should keep your supervisor and co-workers informed about any issues related to malfunctioning of equipment, task completion difficulties and timelines, progress and any other work related issues. Such issues may include:

- Volume of work
- Quality of work
- Time within which work needs to be completed

Since the team, department and organisation are dependent on work being completed at each employee level, it is of primary importance that any problem that may arise during execution of work is communicated immediately to find a resolution quickly.

It is the responsibility of authorities to control:

- Miscommunication between employees
- Misunderstanding between employees
- Increased stress at workplace
- Undesirable outcomes

The following figure highlight the importance of sharing reports:



Fig. 4.2.5. Sharing report with management

4.2.3.4: Seeking Feedback

Explain

You should seek regular feedback from your manager or other authorities to:

1. Ensure quality of the work output
2. Ensure you are completing your tasks as per instructions
3. Identify your areas of strength and weaknesses
4. Gather evidence of satisfactory performance
5. Compliance with work and safety procedures and organisational guidelines and policies

When you receive a feedback you should:

- Thank the person sharing the feedback
- Analyze the feedback to see how it can help you improve your work
- Inform the feedback giver, if possible, how you have planned to implement the learnings from the feedback

The following figure shows an example of feedback form:



Fig. 4.2.6. Receiving feedback

4.2.3.5: Seeking Approval and Accepting Flexibility

Explain

When you are required to do something that is not a part of your usual work routine, you will be expected to seek permissions or approvals from your supervisor or other approval bodies. Ensure you follow the organisational process set up for this and seek approval as shown in the figure:



Fig. 4.2.7. Seeking approval

If required, based on the immediate requirement or a change in long terms plans or strategy, customer expectations and related policies and procedures, your work responsibilities and performance indicators may need to be changed. This may also be required to support your team and accept additional workload. When this happens:

- Discuss this with your supervisor
- Follow protocol to change your work process
- Ensure you receive the new work guidelines from the right authorities and channels
- Communicate your revised responsibilities to the rest of your team

Activity-1

- Conduct a 'Organisation Structure Creation Activity'.
- Ask the students to make group of 5 students.
- Students have to do a demonstration on Organisation Structure Creation Activity.
- One group of Students will have 60 minutes for preparing for demonstration. 30 minutes for demonstration.
- Appreciate learning skill of students and tell correct Activity, if any Activity is wrongly demonstrated.

Activity	Time	Resources
Organisation Structure Creation Activity	2 Hours	Participant Handbook, Notebook, pen, Flipchart / Laptop, Example of Organisation Structure

Notes



Skill India
कौशल भारत - कुशल भारत



सत्यमेव जयते
GOVERNMENT OF INDIA
MINISTRY OF SKILL DEVELOPMENT
& ENTREPRENEURSHIP



N · S · D · C
National
Skill Development
Corporation

Transforming the skill landscape



5. Housekeeping

Unit 5.1 - Need for health, Safety and Security at workplace

Unit 5.2 - Hazards of Mining

Unit 5.3 - Mine Safety equipment

Unit 5.4 - Fire Safety and First Aid

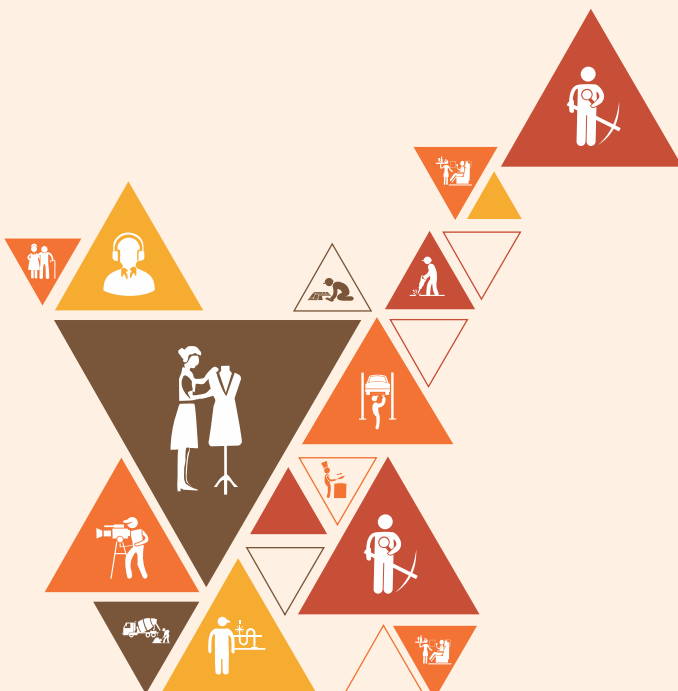

MIN/N0204

Key Learning Outcomes

At the end of this module, students will be able to:

1. Understand the need for health and safety in organizations
2. Identify Potential hazards in mines and follow safety rules
3. Identify various personal safety equipment
4. Understand how to use fire extinguishers and follow fire safety rules
5. Perform basic first aid in various kinds of accidents and injuries

UNIT 5.1: Need for Health, Safety and Security at Workplace

Unit Objectives

At the end of this unit, students will be able to:

1. Understand the need for health and safety standards.
2. Identify some health and safety provisions in organizations.
3. Understand disadvantage of not following health and safety provisions.
4. Identify basic safety management systems in mines

Resources to be Used

- Laptop
- Projector
- White Board
- Marker
- Duster
- Marble mine Health Procedure

Do

- Greet the participants for the day.
- Give Summary of previous Session.
- Ask for any doubts in previous Session.
- Acknowledge for their doubt-raising, if any. Clear the doubts.
- Give details of today's session and what they are going to learn.
- Encourage them to share their thoughts and doubts now and during process of this course.

5.1.1: Health and Safety Standards

Ask

- What are Health and Safety Standards?
- Why Health and Safety Standards need to be followed?

Say

Health and safety of employees at the workplace plays an important role in the overall productivity of an organization. To minimize the employees' exposure to risk organizations usually put some processes or systems in place, for instance, using protective gear, evacuation routes and other safety equipment and instructions where necessary.

Apart from this, organizations may also have detailed guidelines on how to ensure safety and health of employees. This is especially important in the area of mining, as this is a hazardous profession where workers are expected to work in dangerous conditions

Some common steps taken by organizations to ensure employee safety and health are shown in the following figure :



Fig. 5.1.1. Safety Equipment and other arrangement made by organisations

It is the responsibility of both the organization and its employees to follow the guidelines and systems in place and ensure a risk-free work environment for all. Essentially, a healthy and safe workplace is an important factor for enhanced employee productivity.

The Government of India recognizes that safety and health of workers has a positive impact on productivity and economic development. Therefore, its objective is to create a more secure workplace for sustainable growth.

The key obligations and regulations for employers are shown in following figure:

- Employers are responsible for ensuring the health and safety of their employees
- An employer must assess and review the work-related risks faced by his/her employees
- An Employer must make appropriate arrangements for the effective planning, monitoring and reviewing of the preventive measures to control those risks.
- An employer must provide his/her employees with relevant information and training on the risks they face and the preventive measures to control those risks.
- an organisation must complete all the health, safety, security and environmental records required by company and regulatory standards

Fig. 5.1.2. Obligations of employers

5.1.1.1: Some Health and Safety Provisions in Organisation

Explain

Some health provisions provided in organizations are shown in following figure :

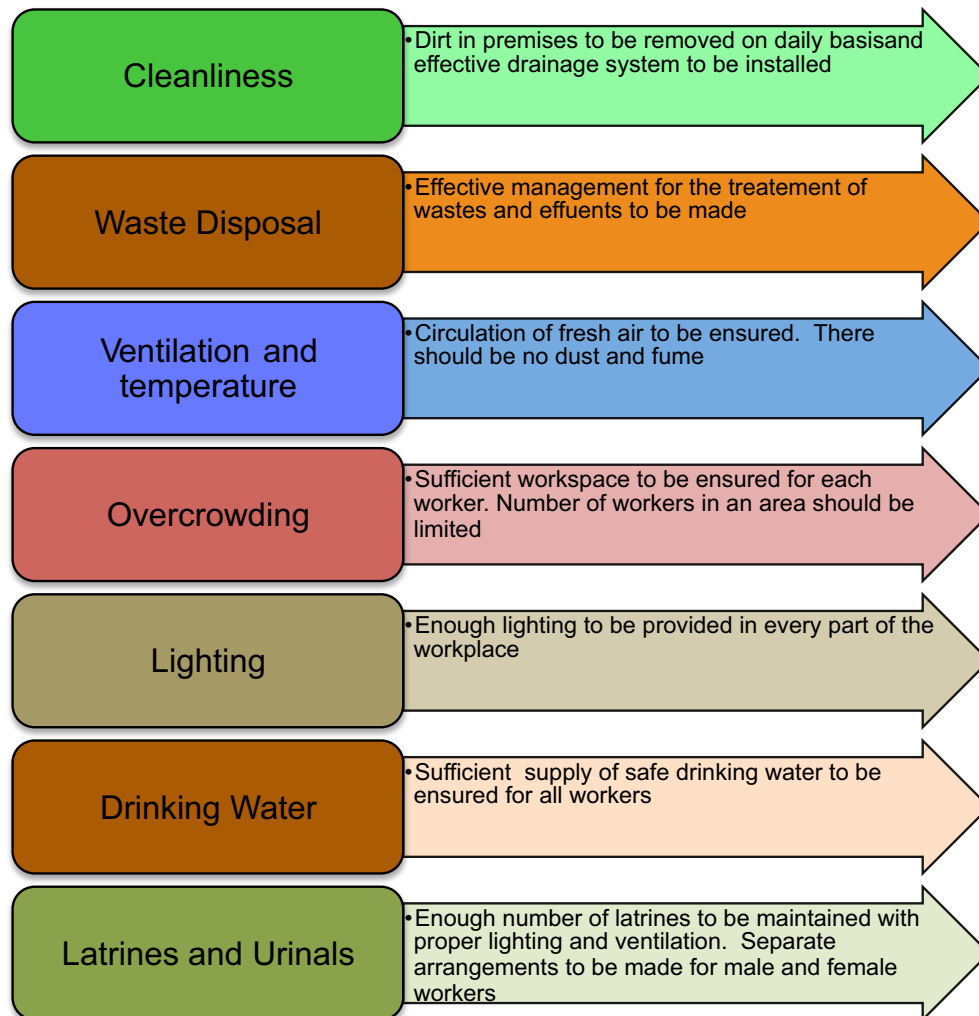

Fig. 5.1.3. Health provisions in organisation

Some safety provisions in organizations are shown in following figure :



Fig. 5.1.4. Safety provisions in organisation

Tips

Organisations and employers are levied huge penalties and even imprisonment if they fail to comply with the mandated health and safety regulations.

5.1.1.2: Disadvantages of not following Health and Safety Policies in Organisation

Explain



Unsafe and unhealthy work environments are dangers to an employee, employer, or the general organization. Implementing the maintaining high standards of health, safety and security at workplace play a significant role in running a successful business.

Inability to maintain the health and safety standards also lead to low employee morale, attrition, customer dissatisfaction, and ultimately business failure, as shown in following figure :

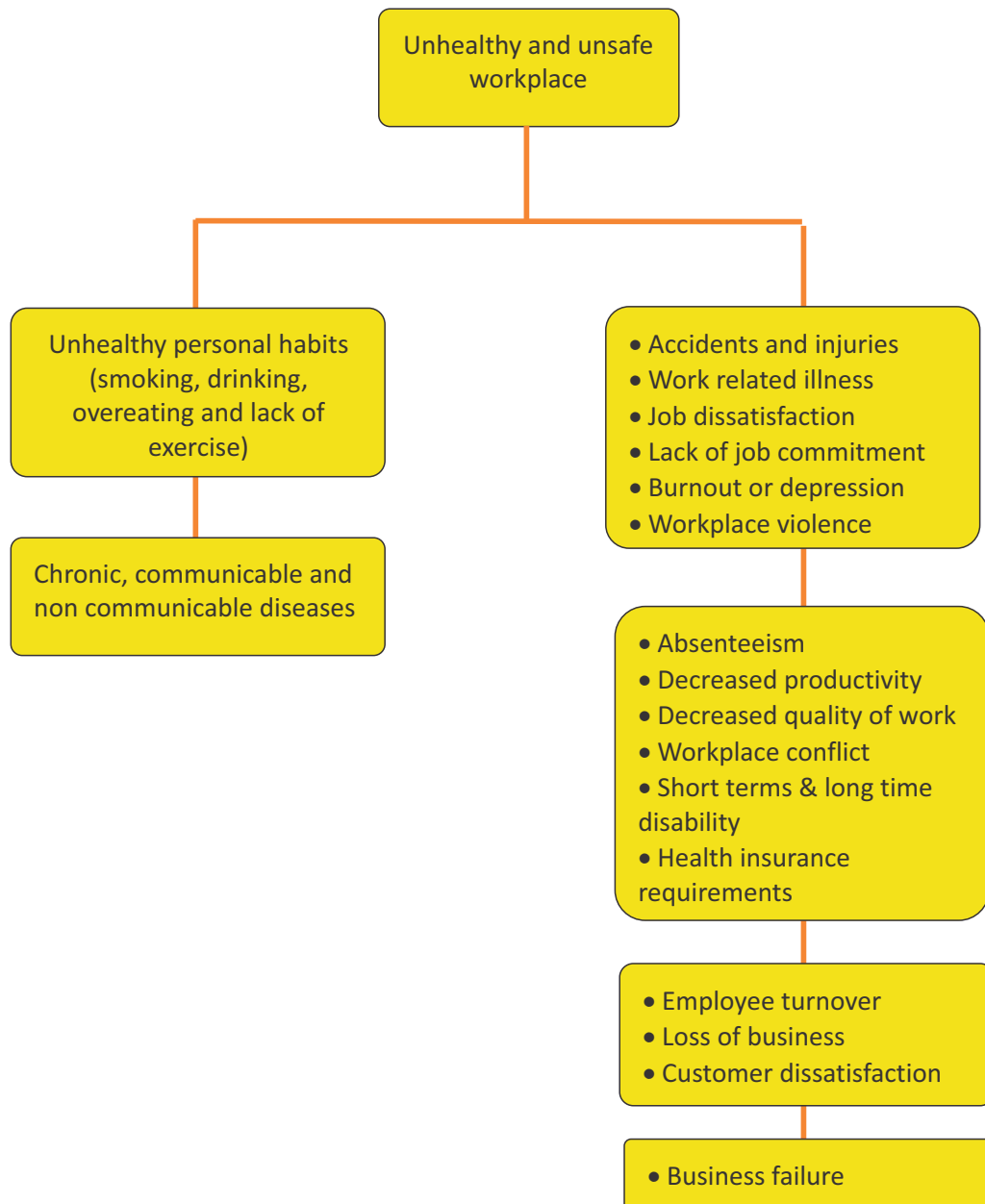

Fig. 5.1.5. Effects of inability to maintain health standards

5.1.2: Basic Safety Management Systems in Mines

Explain

Following are some of the basic requirements of safety management systems in mines.

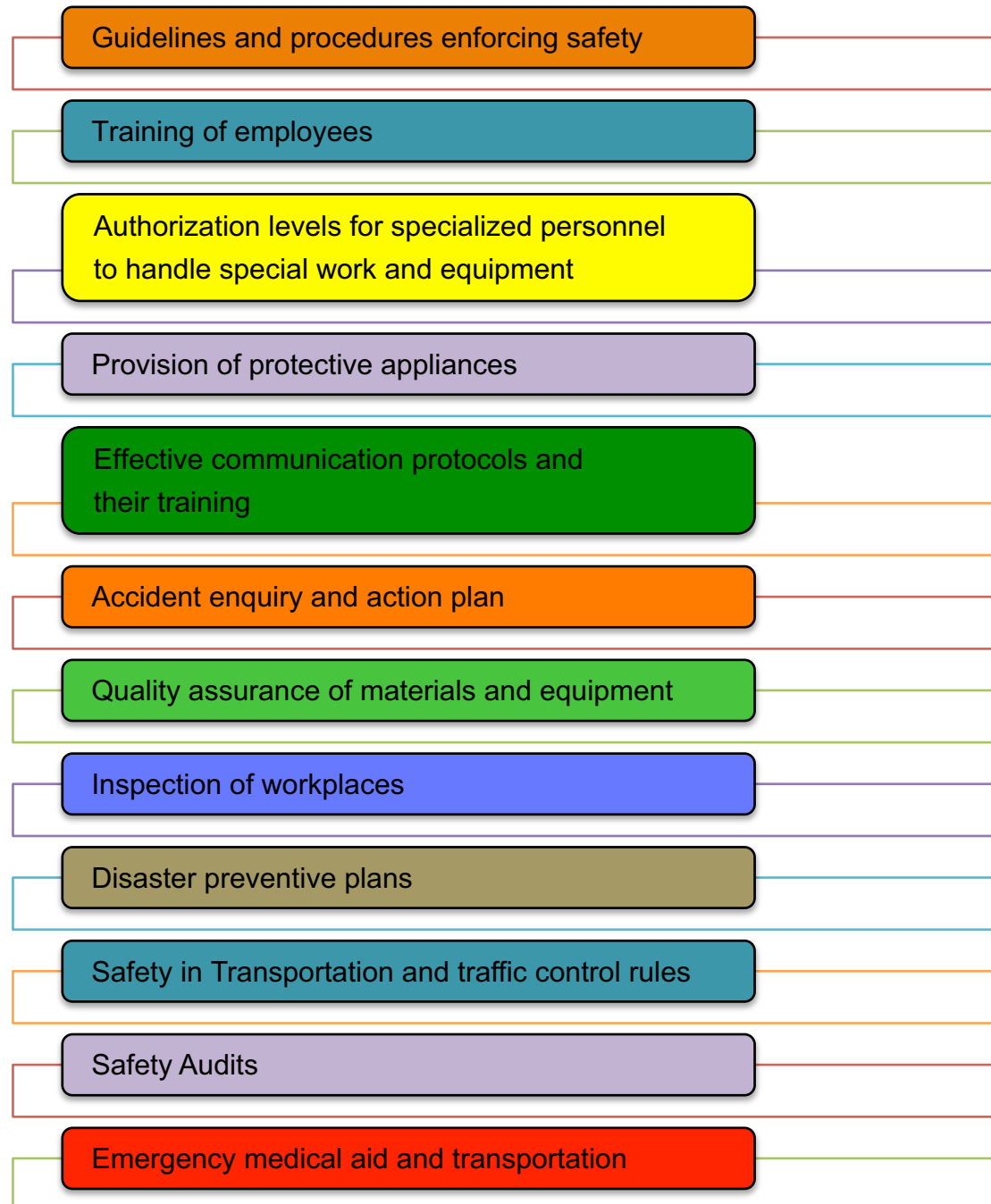

Fig. 5.1.6. Mine Safety management provisions

Activity-1

- Conduct a 'Presentation on Safety Provisions in Organisation Activity'.
- Ask the students to make group of 5 students.
- Students have to do a Presentation on Safety Provisions in Organisation Activity.
- One group of Students will have 60 minutes for preparing for demonstration. 30 minutes for demonstration.
- Appreciate learning skill of students and tell correct Activity, if any Activity is wrongly demonstrated.

Activity	Time	Resources
Presentation on Safety Provisions in Organisation Activity	2 Hours	Participant Handbook, Notebook, pen, Flipchart / Laptop,

UNIT 5.2: Hazards in Mines

Unit Objectives

At the end of this unit, students will be able to:

1. Understand the role of DGMS.
2. Identify various hazards in mines and take necessary precautions.
3. Follow proper waste management guidelines.

Resources to be Used

- Laptop
- Projector
- White Board
- Marker
- Duster
- Details and Photos of Mine Hazards
- Waste Management Guidelines

Do

- Greet the participants for the day.
- Give Summary of previous Session.
- Ask for any doubts in previous Session.
- Acknowledge for their doubt-raising, if any. Clear the doubts.
- Give details of today's session and what they are going to learn.
- Encourage them to share their thoughts and doubts now and during process of this course.

5.2.1: Conditions in Mines

Ask

- What is Hazard?
- Is Mine condition hazardous?

Say

It is well known that mining is a hazardous profession. Just like in any other industrial accidents, careless acts and unsafe conditions of work lead to accidents.

Other than stalling the entire operation or causing heavy financial losses, the aspect of occupational health hazards in mining industry is critical as it may lead to loss of lives or serious injuries. Therefore it is important to understand what can lead to unsafe conditions in mining and also how these can be prevented.

Following figures shown the hazardous work conditions in mines :



Fig. 5.2.1. Hazardous conditions in Mines

5.2.2: Roles and Functions of DGMS

Elaborate

Directorate General of Mines Safety, commonly known as DGMS, has its headquarters in Dhanbad. The entire country is divided into eight zones, each under the charge of a Deputy Director General of Mines Safety. There are three to our Regional offices under each zonal office. Each region is under the charge of a Director of Mines Safety.

The mission of DGMS is the reduction in risk of occupational diseases and casualties to persons employed in mines

It does this by :

- Drafting appropriate legislation and setting standards.
- Overseeing compliance thereof, inspecting mines, reporting and enquiring accidents.
- Conducting a variety of training, promotional and awareness initiatives for creating an environment in which safety is given due priority.



Fig. 5.2.2. DGMS Logo

5.2.3: Hazards in Mines

Explain



Workers employed in the mines are exposed to a number of hazards at work which adversely affect their health. The following figures shows the key causes of accidents in mines.

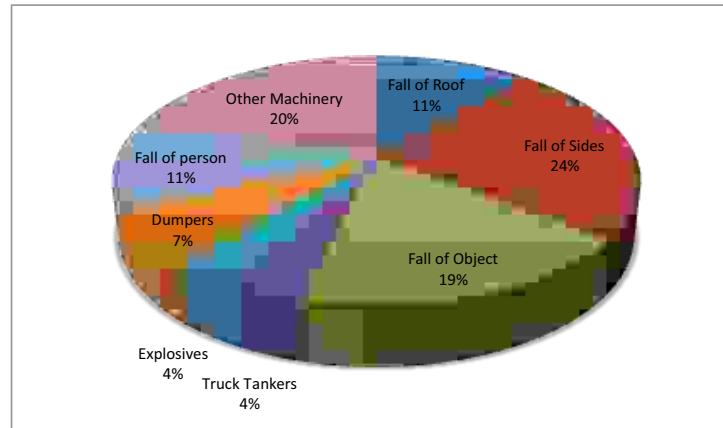

Cause-wise distribution of fatal accidents in non-Coal Mines in 2010

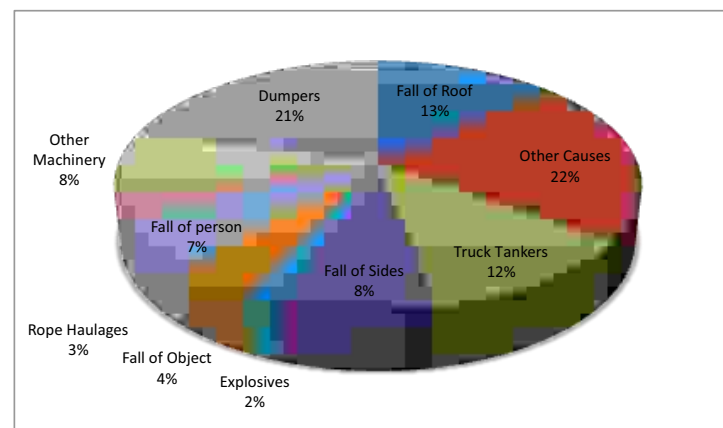

Cause-wise distribution of fatal accidents in Coal Mines in 2010

Fig. 5.2.3. Mine Accident Causes

5.2.3.1: Roof Fall

Explain



- Accidents can happen due to fall of roof, fall of side, bumps, air blast, landslide, collapse of pillar or overhanging ground. Roof fall is one of the predominant causes of accidents in underground mines.
- There can be various causes for this, including unsafe methods of work and collapse of support.
- Timber support is often used in mines, which does not always provide adequate holding strength. Steel supports with roof bolts are more stable. The supports also need to be provided before miners are engaged.
- Many of the roof fall accidents occur within 30 minutes of blasting operations, which indicates sufficient time was not provided for the roof to settle down before engaging minors.

To avoid roof fall

- Ensure you have proper training before preparing support for the roof.
- Do not hurry or be careless in preparing support.
- Maintain safety standards as prescribed by the organization.



Fig. 5.2.4. Mine Safety Signs

In case your work requires lifting heavy loads, be careful and take extreme precaution before you lift the loads. If possible, split and load among two people or do it in turns. Follow the right lifting practices. The following shows process to lift heavy loads:

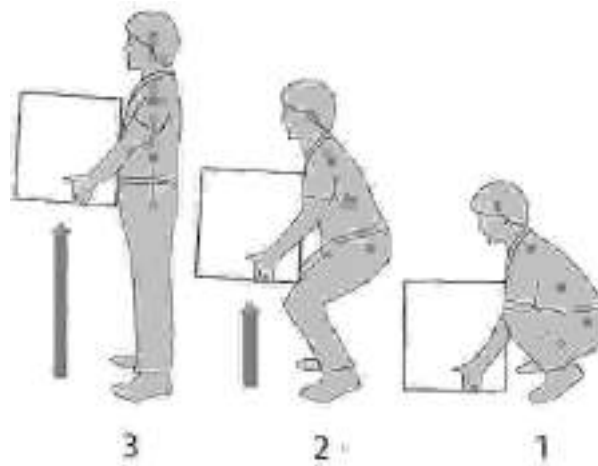

Fig. 5.2.5. Lifting heavy load

5.2.3.3: Mine Fire

Explain

Following can be major causes of fire in mines :

- Friction from defective bearings in machines such as conveyor belts, wheels, brakes on vehicles or other equipment.
- Internal combustion engines, exhaust systems , hot surfaces
- Spontaneous heating of coal in waste or broken coal near mine area
- Sparks from cutting machinery, electrical and mechanical machinery and equipment
- Short circuits and earth faults on electrical equipment.
- Explosives and detonators, compression of air gases

To control fire in mines :

- Avoid or control sources of ignition
- Minimise the amount of flammable materials below ground
- Detect fires and give warning in the event of fire.
- Where possible, use fire resistant fluids instead of mineral oils.
- Use only fire resistant conveyor belting.
- Use firedamp drainage systems to prevent flammable gas entering the general body of mine air
- Ensure that rubbish and other flammable waste material is removed promptly, for example paper, wood, plastic and old vehicle tyres
- Avoid hot surfaces and frictional sparking in machines, ensuring proper lubrication
- Check that moving parts are not unintentionally rubbing against fixed objects.
- Be mindful of safety signs.

The following figure shows safety signs of fire and explosive :



Fig. 5.2.6. Safety sign for fire and explosives

5.2.3.4: Chemical Hazards

Explain

Mines often have poisonous gasses or chemicals which are potential causes of hazards. Necessary facilities for monitoring the environmental parameters in respect of Methane & carbon Monoxide should be provided at mines. Facilities of continuous type monitoring should be installed while handling any chemicals or cleaning agents, ensure you :

- Wear gloves and other safety equipment, and avoid skin contact with the chemical
- Keep your eyes and nose protected and away from the chemicals
- Do not mix one chemical with another
- Do not swallow or take in any chemicals. If swallowed by mistake report immediately and take the victim to a doctor.

The following figure shows the chemical safety signs :

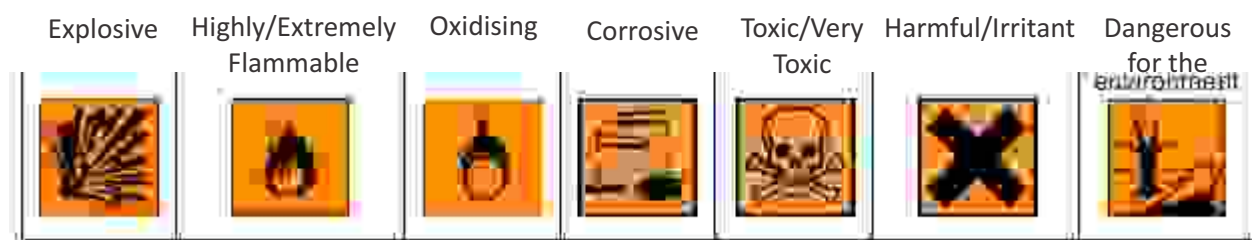

Fig. 5.2.7. Chemical Safety Signs

5.2.3.5: Ergonomic Hazards

Explain

Ergonomic hazards are those that affect the musculo – skeletal system of an employee. Ergonomic injuries include strains, sprains, and other problems.

Different causes of ergonomic hazards include :

- Limited workspace
- Repetitive task or motion
- Shiftwork (especially, night shift jobs)
- Mental and physical workload

Controlling Ergonomic Hazards

Some tips for controlling ergonomic hazards are as follows :

- Take rest breaks. Rotate tasks.
- Alternate between the left and right hands. Keep your back and wrists straight. Keep your elbows close to your body.
- Avoid extreme reaches.
- Handle lifting loads with care.
- Report early symptoms , such as discomfort or numbness, to your supervisor

Other potential hazards

- Dust and dust – borne diseases
- Noise
- Vibration
- Mine workers must ensure they were proper safety equipment while working in mine sites.

5.2.4: Waste Management

Explain



If waste in mines is not dealt with properly, it causes serious environmental issues in the surrounding areas. Following are some things to keep in mind as basic waste management rules :

- Use only authorized waste disposal areas
- Do not store lubricants in open or unlabeled containers.
- Do not pour used engine oil into sewers, waterbodies or drains or on the ground.
- Look out for proper bins. Black bins are used for industrial waste, and separate bins are used for other kind of waste.

Activity-1



- Conduct a 'Presentation on Safety Hazards in Mines Activity'.
- Ask the students to make group of 5 students.
- Students have to do a Presentation on Safety Hazards in Mines Activity.
- One group of Students will have 60 minutes for preparing for demonstration. 30 minutes for demonstration.
- Appreciate learning skill of students and tell correct Safety Hazards, if any Hazard is wrongly demonstrated.

Activity	Time	Resources
Presentation on Safety Hazards in Mines Activity	2 Hours	Participant Handbook, Notebook, pen, Flipchart / Laptop,

UNIT 5.3: Mines Safety Equipment

Unit Objectives

At the end of this unit, students will be able to:

1. Identify basic personal protective equipment.

Resources to be Used

- Laptop
- Projector
- White Board
- Marker
- Duster
- Mine Safety Equipment

Do

- Greet the participants for the day.
- Give Summary of previous Session.
- Ask for any doubts in previous Session.
- Acknowledge for their doubt-raising, if any. Clear the doubts.
- Give details of today's session and what they are going to learn.
- Encourage them to share their thoughts and doubts now and during process of this course.

5.3.1: Mining Protective Equipment

Ask

- What are Mine Safety Equipment?
- Why Mine Safety Equipment is required?

Say

Every person in mine must wear safety gadgets to be provided by the employer. Following are some key mining equipment typically used. Personal Protective Equipment (PPE) is worn to minimize exposure to a variety of hazards, and include gloves, foot and eye protection, protective hearing devices (earplugs and muffs), hard hats, respirators and full body suits. The following figure shows personal protective wear of mines.



Fig. 5.3.1. Personal Protective wear of miners

The following figure shows caring for safety helmets :



Fig. 5.3.2. Caring instructions for Safety Helmet

Be careful and wear required PPE when you see signs such as shown in the following figure :



Fig. 5.3.3. Mine Safety Signs

Activity

- Conduct a 'Demonstration on Mine Safety Sign Identification Activity'.
- Ask the students to make group of 5 students.
- Students have to Create Demonstration on Mine Safety Sign Identification Activity.
- One group of Students will have 60 minutes for creating presentation. 10 minutes for presentation.
- Appreciate identification skill of students and tell correct Mining Method, if any Mining Method is wrongly quoted.

Activity	Time	Resources
Demonstration on Mine Safety Sign Identification Activity	2 Hours	Participant Handbook, Notebook, pen, Flipchart / Laptop, Mine Safety Signs

UNIT 5.4: Fire Safety and First Aid

Unit Objectives

At the end of this unit, students will be able to:

1. Identify source of fire in mines.
2. Understand how to use fire extinguishers.
3. Perform first aid in various situations.

Resources to be Used

- Laptop
- Projector
- White Board
- Marker
- Duster
- Fire Extinguisher
- First Aid Box
- First Aid Equipment

Do

- Greet the participants for the day.
- Give Summary of previous Session.
- Ask for any doubts in previous Session.
- Acknowledge for their doubt-raising, if any. Clear the doubts.
- Give details of today's session and what they are going to learn.
- Encourage them to share their thoughts and doubts now and during process of this course.

5.4.1: Fire Safety

Ask

- Why Fire Safety is important?
- What are the equipment for Fire Safety?

Say

Fire can be a common hazard in mines. Anything that can burn or is a potential fuel can cause a fire. Before we know what measures can be taken to fight fire, let us understand that causes fire to spread.

Fire is difficult to extinguish if there is :

- Supply of oxygen to sustain the fire. This can be removed using fire extinguishers.
- Enough heat to continue the burning. This can be eliminated with water.
- Presence of fuel that can sustain the fire. The fuel should be removed immediately.

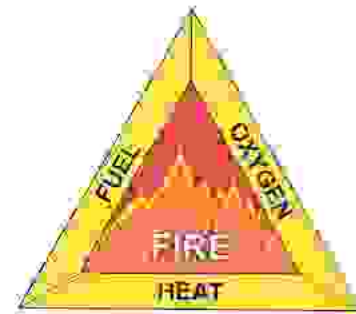

Fig. 5.4.1. Causes of Fire

The first step in fire w/extinguishing must be to eliminate these causes.

5.4.1.1: Fire in Mines

Explain



In mines, the following are some potential fuels available :

- Firedamp (a naturally occurring mixture of hydrogen gases).
- Coal/coat dust
- Wood
- Tires and plastic materials
- Minerals oils and grease
- Bottled gases such as acetylene and propane
- Explosives

5.4.1.2: Fire Extinguishers

Explain



Various kinds of fire extinguishers are available based on the type of fire. There are four key classes of fire (fuel). Using an incorrect type of extinguisher may cause more harm than good. Usually the body of the fire extinguisher will have the labels explaining which class of fire they can be used for. The different types of fire extinguisher are :

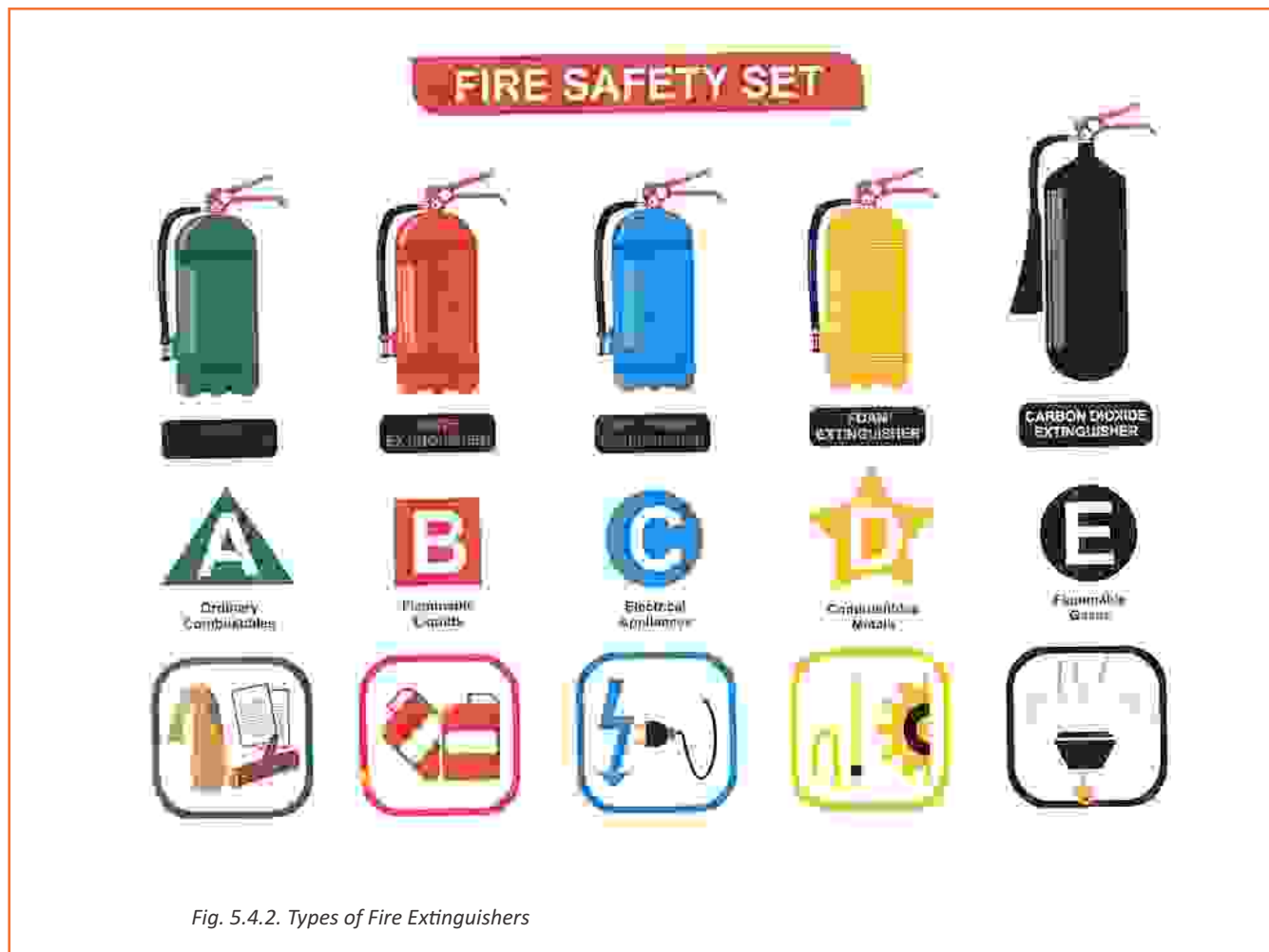

Fig. 5.4.2. Types of Fire Extinguishers

5.4.1.2.1: Using a Fire Extinguisher

Explain

The following figure lists the four main steps below to remember how to use a fire extinguisher :



Fig. 5.4.3. Using Fire Extinguisher

The following figure shows the various parts of a fire extinguisher :



Fig. 5.4.4. Parts of Fire Extinguisher

5.4.1.2.2: Steps for using Fire Extinguisher

Explain

Steps to Use Fire Extinguisher

following are the steps for using a Fire Extinguisher:



Fig. 5.4.5. Procedure for using Fire Extinguisher

Tips

Keep the fire extinguisher away from your body. Even after the fire is out, there is a chance of re-igniting. Therefore be alert.

5.4.1.2.3: Things to Remember While Fire Fighting

Explain



- The first step would be to find a way to escape the area with fire, and find help. In case you are helping others in the fire, ensure it does not risk your own safety or the safety of others.
- If the fire is small try to put it out using a fire extinguisher.
- Try to figure out what is burning, so that you can use the right kind of extinguisher.
- If the fire is already spreading quickly, it is best to evacuate the area
- As you evacuate the area, you can try to close entry points as you leave, so as to prevent or slow down the spread of smoke and fire.

5.4.2: First Aid

Explain



First aid is the immediate medical service given to persons who suddenly become injured or ill. The main purpose of first aid is to provide immediate relief to the patient until medical assistance arrives. Every organization must have a first aid kit available as a part of the medical emergency plan. An emergency medical plan should include the various parameters, as shown in following figure :

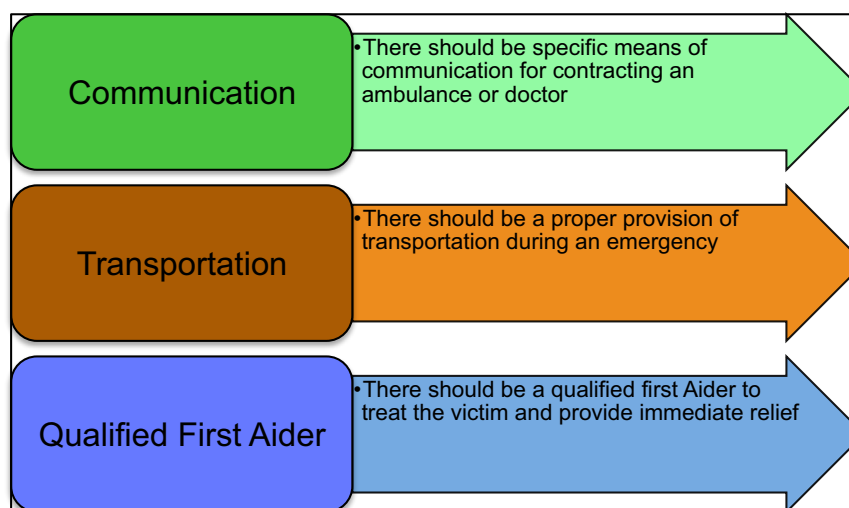

Fig. 5.4.6. Emergency medical plan

5.4.2.1: Knowledge of Emergency Medicines

Explain



Every organization must train its employees with the basic knowledge of emergency medicines that can be used as primary medical aid if a doctor or hospital is not available nearby. Here are some groups of medicines that can be given in case of an emergency are shown in following figure :

5.4.2.2: Do's and Don'ts of While Providing First Aid

Demonstrate

While providing first aid to an employee at workplace, certain do's and don'ts must be strictly following to avoid unusual circumstances.

The Do's that must be following while providing first aid are shown in following figure :

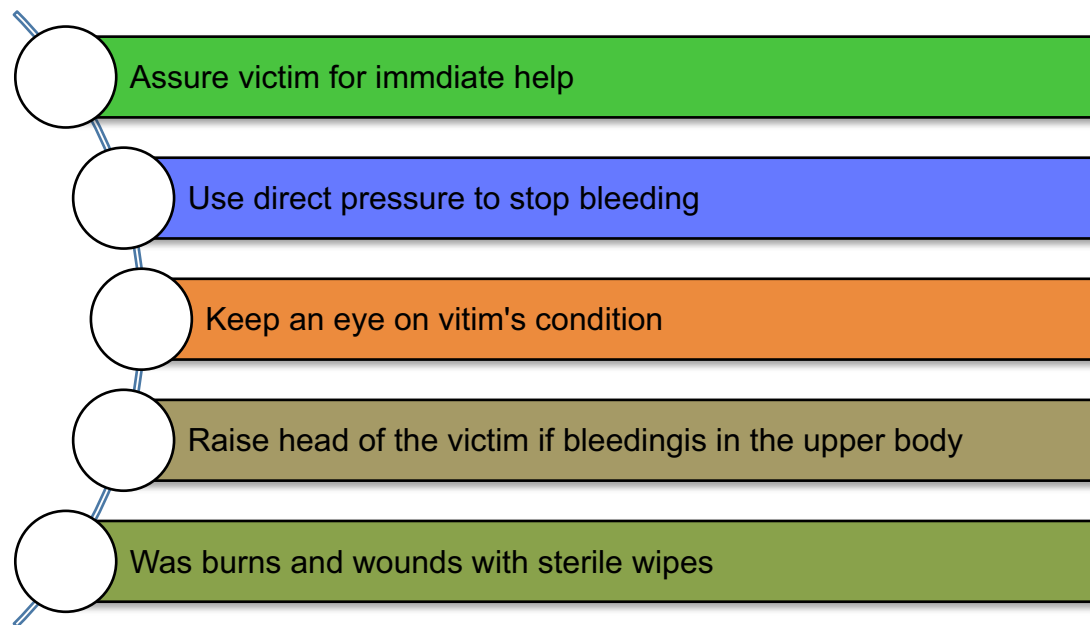

Fig. 5.4.9. Do's of providing first aid

The don'ts that must be following while providing first aid are shown in following figure:

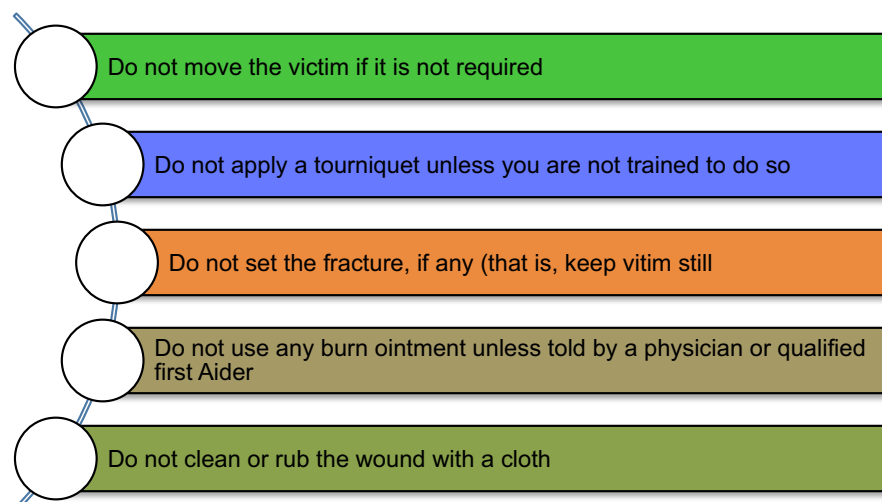

Fig. 5.4.10. Don'ts of providing first aid

5.4.2.3: Steps to Provide First Aid

Demonstrate



Every employee in an organization must be aware of how to provide basic first aid treatment to a colleague in case of an emergency.

The basic steps that should be followed while providing first aid are shown in following figure :

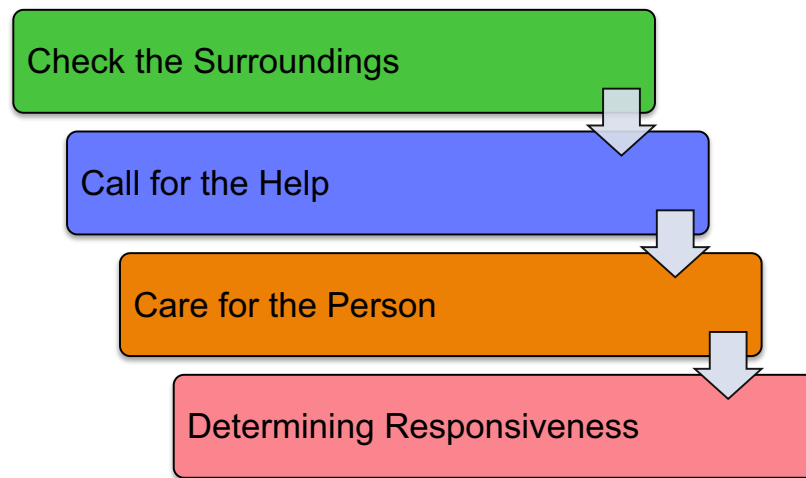

Fig. 5.4.11. Steps for providing first aid

5.4.2.3.1: Calling Doctor or Ambulance

Say



When a medical emergency occurs in an organization, the first thing is to provide first aid to the victim. Thereafter, employees should call a doctor or an ambulance or take the victim to a hospital, as shown in following figure :



Fig. 5.3.12. Seeking ambulance help

A few simple steps to call an ambulance are shown in following figure :

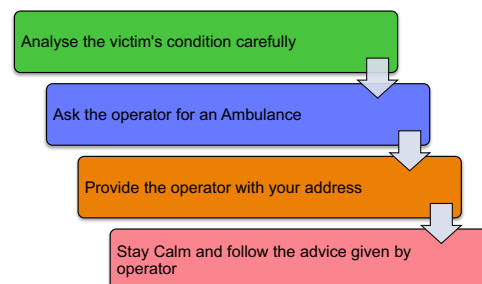

Fig. 5.3.13. Steps to call an ambulance

5.4.2.3.2: Narrating the Medical Situation

Demonstrate



Knowing how and when to report a hazard can be crucial in reducing the effect of the hazard.

- 1 Immediately report to the relevant person
- 2 Warn other employees who may be affected

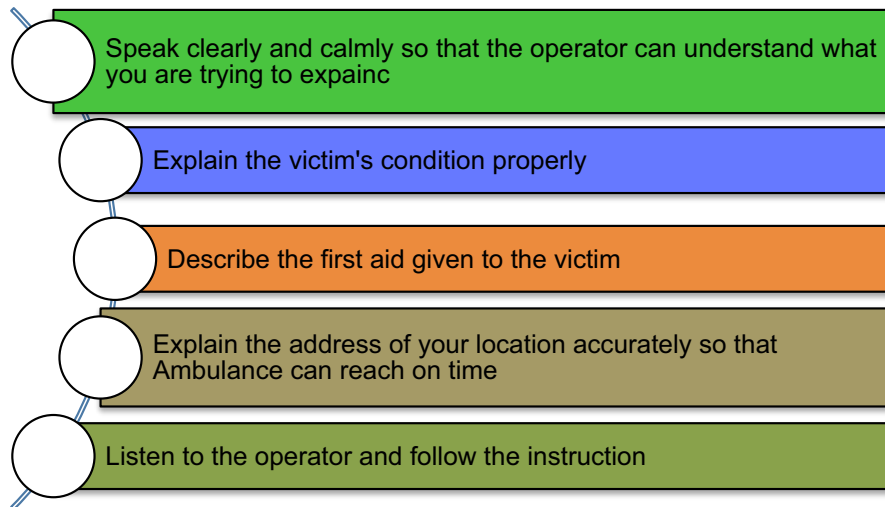

Fig. 5.4.14. Narrating a medical situation

5.4.2.3.3: Reporting Issues to Concerned Authority

Demonstrate



“Prevention is better than cure.” This saying is most relevant to the safety and security at the workplace. A timely reporting of health and safety concern can save a great deal of money and physical injuries. Employees have the responsibility to report any identified breaches in the safety and health plans and procedures to the designated person. All accidents in the workplace should be reported to the supervisor and finally, the employer. For instance, the absence of or defect in any equipment or protective device that may endanger the life of any employee, should be immediately reported to the concerned authority, as emphasized in the following figure.



Fig. 5.4.15. Accident report

All organizations must train their staff members to handle any emergency situations. When an emergency occurs, employees must know how to call an ambulance and narrate the operator about the situation so that the ambulance can arrive on time. The key points for narrating a medical situation effectively over phone are shown in following figure :

5.4.3: Providing First Aid

Say

Some procedures to be followed to provide first aid in various situations such as providing CPR, first aid for bone injuries, first aid for burns, electrocution first aid. Etc.

5.4.3.1: Providing CPR

Demonstrate

CPR or cardiopulmonary resuscitation is a first aid technique useful in various emergencies, such as unconsciousness, heart attack or near drowning, in which someone's breathing or heartbeat has stopped.

Steps to do CPR

In case you are not trained to perform CPR, you can follow the below steps to perform a hands only CPR.

1. Put the heel of your hand on the breastbone at the centre of the person's chest. Put your other hand on top of your first hand. Lock your fingers.
2. Position yourself with your shoulders above your hands.
3. Using the weight of your entire body, press straight down by 5-6cm on their chest.
4. Keep your hands on their chest, release the pressure and allow the chest to come back to its original position.
5. Repeat these steps at a rate of 100 to 120 times per minute till medical help arrives.

The following figure shows how to provide CPR :

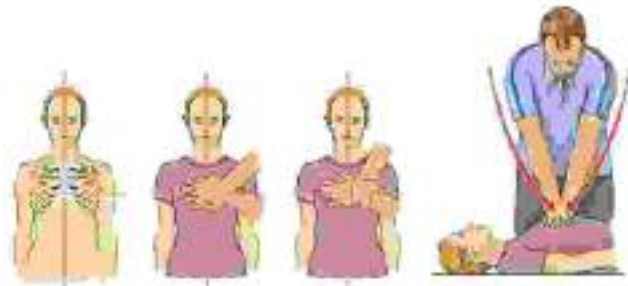
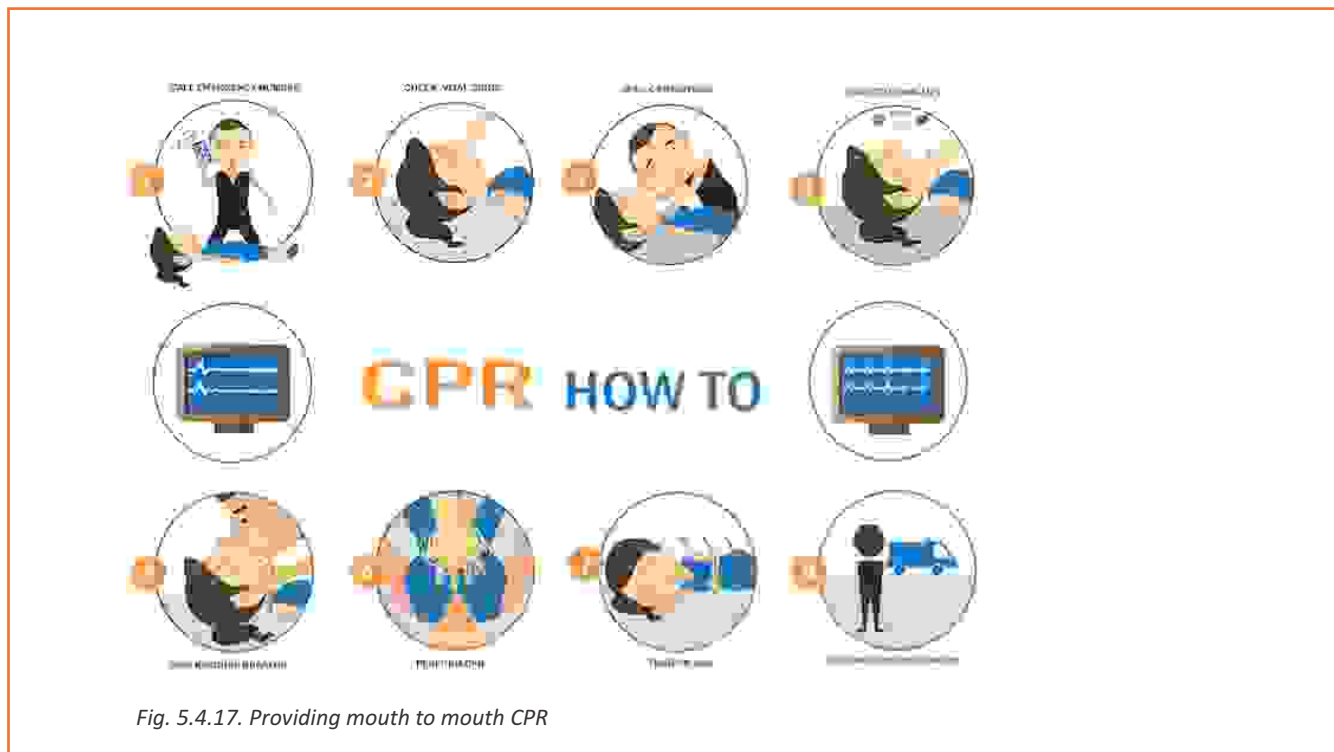

Fig. 5.4.16. Providing CPR

In case you are trained to do mouth to mouth CPR, follow the below steps :

6. Put the heel of your hand on the centre of the person's chest. Put the other hand on top of it and press down by 5-6 cm at a rate of about 100 to 120 compressions per minute.
7. After each 30 chest compressions, give two rescue breaths.
8. To provide rescue breath, tilt the person's head gently and lift the chin up with two fingers. Pinch the person's nose. Seal your mouth over their mouth. Now steadily blow into their mouth for about one second. See if their chest rises. Give two rescue breaths.
9. Continue with cycles of 30 chest compressions and two rescue breaths till help arrives. The mouth-to-mouth CPR is shown in the following figure :



5.4.3.2: Bleeding

Demonstrate



Bleeding may be of the following kind :

- Minor bleeding – slow flow of blood in smaller amount.
- Bleeding through arteries – considerable amount of bleeding in gushes, bright red blood.
- Bleeding from vein – dark red blood, slow but steady blood flow
- Internal bleeding – cannot be seen but results in vomiting or spitting, and may be quite dangerous.

The following figure shows the types of bleeding :



Fig. 5.4.18. Types of Bleeding

For minor bleeding or bleeding from vein :

- 1 Ask the person to remain calm and make the person lie down if the bleeding is considerable.
- 2 If the wound is on an arm or leg, raise the limb above the heart to slow bleeding.
- 3 If the wound is small, gently hold the area under running water.
- 4 If the wound is large, do not try to clean. Apply firm pressure to the wound with a folded cloth or bandage for about 10 minutes as shown in the following figure :



Fig. 5.4.19. Applying pressure

If bleeding does not stop, do this for another 10 minutes :

- 5 Offer the person a glass of cold water.
- 6 Arrange for immediate medical help.
- 7 Wear clean gloves and clean your hand while applying first aid.

5.4.3.3: Fracture

Demonstrate

Signs of bone injury can be any of the following :

- 1 Excessive pain at the area of the injury that seems to worsen every minute.
- 2 Swelling, numbness, or bluish color of the wounded area
- 3 Deformity of the limb or joint if the injury is in the arm or leg
- 4 Bone protruding through the skin
- 5 Heavy bleeding at the wound area

Following are some actions you can take as first aid :

- 1 If the person is unconscious and / or not breathing or moving, call for medical help immediately and begin CPR.
- 2 Try to stop the bleeding by applying to the wound with a clean gauze, bandage or a clean cloth.
- 3 The person may be in shock, and experience dizziness, weakness, pale skin, shortness of breath, and increased heart rate. Make the person lie quietly with the feet elevated about 12 inches. Cover the person with a blanket to maintain body warmth.
- 4 Take care not to move the wounded area in case the wounded person is being moved. You can make a splint (Refer to Fig. 5.35) by folding a piece of cardboard or newspaper or wooden support, and place it gently under the limb. Carefully tie the splint to the wounded area with pieces of cloth as shown. Do not apply a tourniquet.
- 5 Apply cold compress or ice to the wounded area. In case you are using ice, place a cloth between the skin and the ice.



Fig. 5.4.20. Splint

5.4.3.4: If a Person is Unconscious

Demonstrate

Unconsciousness may be caused because of various reasons such as weakness, injury, dehydration or problems with the heart or nervous system. In case a person becomes unconscious :

- 1 Ask for medical help immediately. Keep the person warm. Do not place a pillow under the person's head.
- 2 Check the person's airway, breathing and pulse every minute. If required begin CPR.
- 3 If the person is breathing and lying on their back, and in case there is not spinal injury, carefully roll the person towards on their side and towards you. Bend the top leg so that the hip and knee is at right angles as shown in the following figure :



Fig. 5.4.21. Reviving unconscious person

- 4 Tilt the head gently to keep the airway open. If breathing or pulse stops, roll the person on their back and begin CPR.
- 5 If there is a spinal injury, leave the person in the same position they were in. If the person vomits, roll the entire body at a time to their side. Support their back and neck as you roll.
- 6 Try talking to the person by asking simple questions and observing if the person can answer them correctly. Incorrect responses may signify a changed mental state.
- 7 In case the person is unconscious due to lack of food or dehydration , let the person sip a sweet drink slowly once they gain consciousness. Do not give an unconscious person any food or drink.

5.4.3.5: First Aid for Burns

Demonstrate

Fire is a frequent safety hazard in mines. The first step you should take in case of burn is to stop the burning to prevent a more severe burn. The process to do this in various kinds of burns is :

- 1 **For heat burns :** Put out the flames by covering them with a blanket or water. In case the victim's clothing catches fire, do not panic. Make the person stop, drop and roll on the ground to put out the flames.



Fig. 5.4.22. Burn wound

- 2 **For electrical burns :** Separate the victim from the electrical source. Check for breathing and a heartbeat. If the victim is not breathing or does not have a heartbeat, call for medical help immediately and perform CPR.
- 3 **For chemical burns :** First, identify what chemical caused the burn. Gently, run cool water on the burn for at least 20 minutes or till medical help arrives. Do not try to use any acid or alkali as this can cause a chemical reaction that worsens the burn. Do not put any lotion or ointment on the burn.
- 4 **For tar or hot plastic burns :** Immediately run cold water over the hot tar or hot plastic to cool the tar or plastic. Remove any jewellery or clothing from the burn area, unless these are stuck to the skin.
- 5 **For cold temperature burns :** Warm the affected areas. The small areas of the body such as ears, face, nose, fingers, toes that are frozen can be warmed by blowing warm air on them, covering them with clothes or putting warm water on them.

In all cases, call for help immediately.

5.4.3.6: Electrocution First Aid

Demonstrate

In case of electrical shock, the first think to do is separate the person from current's source. To turn off power :

1. Unplug any machine which may be the cause of electrocution. Shut off power via the circuit breaker, fuse box, or switch.
In case you cannot turn off power :
2. First ensure you stand on something that is dry and non-conductive, such as dry newspapers, telephone book or wooden board.
3. Next, try to separate the person from current using non-conductive object such as a wooden, rubber or plastic object, chair etc. as shown in the following figure :



Fig. 5.4.23. First aid for electrocution

4. However do not try to separate the person from current in case you feel a tingling sensation in your legs or your lower body. Move to a safe area where you can wait for lines to be disconnected.

Once the person has been separated :

5. Give ample amount of water mixed with sodium bicarbonate to the electrocuted.
6. Make them inhale table salt.
7. If the person has any pain in throat, avoid providing anything to drink unless medical help advises you to.

5.4.3.7: Unwanted Object in Eyes

Demonstrate

In case a victim has a foreign object in their eyes, do the following :

1. Let the victim stand facing the light. Gently separate the upper and lower eyelids with two fingers and check the eye.
2. In case you can see something the unwanted object, use the corner of a clean, wet cloth to remove the object (Refer to Fig. 5.39) . However be careful not to hurt the eye further.
3. If this does not work, pour clean water gently on the eye to flush it out clean water or ask the victim to immerse his face in a bucket of water and blink.
4. Be careful not to apply any pressure.
5. In all cases, request medical help immediately.



Fig. 5.4.24. Removing unwanted object in eye

5.4.4: Emergency Evacuation

Demonstrate

An emergency plan is a set of instructions that outlines what employees at the workplace should do in the event of an emergency. On the other hand the evacuation plan provides a set of procedures to be used by the occupants of a building in an emergency. Rescue plan includes the plans for rescue in case workers are trapped in hazardous situations.

Every mine should have an emergency and evacuation plan. An employer should explain the employees about the goal of protecting lives and property in the event of an emergency and include all employees in designing and implementing the emergency plan.

Tips

While developing an emergency plan, consider the worst case scenarios for wide variety of potential disasters that could occur in the workplace. A sample emergency evacuation plan is shown in following figure :



Fig. 5.4.25. A sample emergency evacuation plan

General training for employees on emergency and evacuation plans should address the following :

- 1 Individual roles and responsibilities
- 2 Potential threats and hazards and protective actions.
- 3 Warning and communications procedures.
- 4 Emergency response procedures.
- 5 Location and use of common emergency equipment
- 6 Emergency shutdown procedures

Knowing the meaning of the symbols used in evacuation plans significantly helps during an emergency situation. Following figure shows the symbols used in evacuation plans



Activity-1

- Conduct a 'Demonstration on using a Fire Extinguisher Activity'.
- Ask the students to make group of 5 students.
- Students have to do a Demonstration on using a Fire Extinguisher Activity.
- One group of Students will have 60 minutes for preparing for demonstration. 30 minutes for demonstration.
- Appreciate learning skill of students and tell correct activity, if any activity is wrongly demonstrated.

Activity	Time	Resources
Demonstration on using a Fire Extinguisher Activity	2 Hours	Participant Handbook, Notebook, pen, Flipchart / Laptop, Fire Extinguisher, Fire to Extinguish

Activity-2

- Conduct a 'Demonstration on Providing CPR Activity'.
- Ask the students to make group of 5 students.
- Students have to do a Demonstration on Providing CPR Activity.
- One group of Students will have 120 minutes for preparing for demonstration. 30 minutes for demonstration.
- Appreciate learning skill of students and tell correct activity, if any activity is wrongly demonstrated.

Activity	Time	Resources
Demonstration on Providing CPR Activity	2 Hours	Participant Handbook, Notebook, pen, Flipchart / Laptop, Person for giving Demonstration

Activity-3

- Conduct a 'Demonstration on Providing First Aid during Bleeding Activity'.
- Ask the students to make group of 5 students.
- Students have to do a Demonstration on Providing First Aid during Bleeding Activity.
- One group of Students will have 120 minutes for preparing for demonstration. 30 minutes for demonstration.
- Appreciate learning skill of students and tell correct activity, if any activity is wrongly demonstrated.

Activity	Time	Resources
Demonstration on Providing First Aid during Bleeding Activity	2 Hours	Participant Handbook, Notebook, pen, Flipchart / Laptop, Person for giving Demonstration

Activity-4

- Conduct a 'Demonstration on Providing First Aid during Fracture Activity'.
- Ask the students to make group of 5 students.
- Students have to do a Demonstration on Providing First Aid during Fracture Activity.
- One group of Students will have 120 minutes for preparing for demonstration. 30 minutes for demonstration.
- Appreciate learning skill of students and tell correct activity, if any activity is wrongly demonstrated.

Activity	Time	Resources
Demonstration on Providing First Aid during Fracture Activity	2 Hours	Participant Handbook, Notebook, pen, Flipchart / Laptop, Person for giving Demonstration

Activity-5

- Conduct a 'Demonstration on Providing First Aid for Unconscious Person Activity'.
- Ask the students to make group of 5 students.
- Students have to do a Demonstration on Providing First Aid for Unconscious Person Activity.
- One group of Students will have 120 minutes for preparing for demonstration. 30 minutes for demonstration.
- Appreciate learning skill of students and tell correct activity, if any activity is wrongly demonstrated.

Activity	Time	Resources
Demonstration on Providing First Aid for Unconscious Person Activity	2 Hours	Participant Handbook, Notebook, pen, Flipchart / Laptop, Person for giving Demonstration

Activity-6

- Conduct a 'Demonstration on Providing First Aid for Electrocuted Person Activity'.
- Ask the students to make group of 5 students.
- Students have to do a Demonstration on Providing First Aid for Electrocuted Person Activity.
- One group of Students will have 120 minutes for preparing for demonstration. 30 minutes for demonstration.
- Appreciate learning skill of students and tell correct activity, if any activity is wrongly demonstrated.

Activity	Time	Resources
Demonstration on Providing First Aid for Electrocuted Person Activity	2 Hours	Participant Handbook, Notebook, pen, Flipchart / Laptop, Person for giving Demonstration

Key Learning Outcomes

At the end of this module, students will be able to:

1. Understand value system
2. Appreciate the role of digital literacy
3. Understand Money Matters
4. Appreciate the concept of self-employment
5. Who is entrepreneur
6. How to be an entrepreneur

Unit 6.1: Personal Strength and Value System

Unit Objectives

At the end of this unit, students will be able to:

- 1- Explain the meaning of hygiene
- 2- Understand the purpose of Swacch Bharat Abhiyan
- 3- Explain the meaning of habit
- 4- Discuss ways to set up a safe work environment
- 5- Discuss critical safety habits to be followed by employees
- 6- Explain the importance of self-analysis
- 7- Understand motivation with the help of Maslow's Hierarchy of Needs
- 8- Discuss the meaning of achievement motivation
- 9- List the characteristics of entrepreneurs with achievement motivation
- 10- List the different factors that motivate you
- 11- Discuss how to maintain a positive attitude
- 12- Discuss the role of attitude in self-analysis
- 13- List your strengths and weaknesses
- 14- Discuss how to foster a good work ethic
- 15- List the characteristics of highly creative people
- 16- List the characteristics of highly innovative people
- 17- Discuss the benefits of time management
- 18- List the traits of effective time managers
- 19- Describe effective time management technique
- 20- Discuss the importance of anger management
- 21- Discuss the symptoms of stress
- 22- Discuss tips for stress management

Notes for Facilitation

1. Ensure all the required material and equipment related to session is in place and in proper working condition before starting the session.
2. Before beginning the session, ask the students about what they learnt in the last session.
3. Explain the Objectives of the current session.
4. Use power point presentation to describe the topic.
5. Give assignment to measure the student understanding of the topic
6. Ensure that the session plan should be followed according to time duration to complete the course in-time
7. Discuss the assignment questions with the students and provide correct answers.
8. At the end of the session summarize the key learning.

Ask



- What is WHO?
- How is hygiene and health related ?
- What is self actualization in maslows pyramid?
- Why is positive attitude important?
- What is the meaning of ethics?
- What is innovation?
- What is cognitive restructuring?

Unit 6.2: Digital Literacy: A Recap

Unit Objectives

At the end of this unit, students will be able to:

1. Identify the basic parts of a computer
2. Identify the basic parts of a keyboard
3. Recall basic computer terminology
4. Recall basic computer terminology
5. Recall the functions of basic computer keys
6. Discuss the main applications of MS Office
7. Discuss the benefits of Microsoft Outlook
8. Discuss the different types of e-commerce
9. List the benefits of e-commerce for retailers and customers
10. Discuss how the Digital India campaign will help boost e-commerce in India
11. Describe how you will sell a product or service on an e-commerce platform

Notes for Facilitation

1. Ensure all the required material and equipment related to session is in place and in proper working condition before starting the session.
2. Before beginning the session, ask the students about what they learnt in the last session.
3. Explain the Objectives of the current session.
4. Use power point presentation to describe the topic.
5. Give assignment to measure the student understanding of the topic
6. Ensure that the session plan should be followed according to time duration to complete the course in-time
7. Discuss the assignment questions with the students and provide correct answers.
8. At the end of the session summarize the key learning.

Ask

- What is a crusher?
- What does ESC do?
- What is Microsoft Access?
- Explain B2B and C2C?

Unit 6.3: Money Matter

Unit Objectives

At the end of this unit, students will be able to:

1. Discuss the importance of saving money
2. Discuss the benefits of saving money
3. Discuss the main types of bank accounts
4. Describe the process of opening a bank account
5. Differentiate between fixed and variable costs
6. Describe the main types of investment options
7. Describe the different types of insurance products
8. Describe the different types of taxes
9. Discuss the uses of online banking
10. Discuss the main types of electronic funds transfers

Notes for Facilitation

1. Ensure all the required material and equipment related to session is in place and in proper working condition before starting the session.
2. Before beginning the session, ask the students about what they learnt in the last session.
3. Explain the Objectives of the current session.
4. Use power point presentation to describe the topic.
5. Give assignment to measure the student understanding of the topic
6. Ensure that the session plan should be followed according to time duration to complete the course in-time
7. Discuss the assignment questions with the students and provide correct answers.
8. At the end of the session summarize the key learning.

Ask

- Why is investing important ?
- What are recurring accounts ?
- What is the Nature of variable costs?
- What is a private equity?
- What is capital gain tax?
- What is RTGS ?

Unit 6.4: Preparing for Employment & Self Employment

Unit Objectives

At the end of this unit, students will be able to:

1. Discuss the steps to prepare for an interview
2. Discuss the steps to create an effective Resume
3. Discuss the most frequently asked interview questions
4. Discuss how to answer the most frequently asked interview questions
5. Discuss basic workplace terminology

Notes for Facilitation

1. Ensure all the required material and equipment related to session is in place and in proper working condition before starting the session.
2. Before beginning the session, ask the students about what they learnt in the last session.
3. Explain the Objectives of the current session.
4. Use power point presentation to describe the topic.
5. Give assignment to measure the student understanding of the topic
6. Ensure that the session plan should be followed according to time duration to complete the course in-time.
7. Discuss the assignment questions with the students and provide correct answers.
8. At the end of the session summarize the key learning.

Ask

- Why is preparation important for interview ?
- What will you include in personal skills ?
- Why do you want the job-reasoning ?
- How will you identify strengths ?
- What does CV stands for ?
- What is RTGS ?

Unit 6.5: Understanding Entrepreneurship

Unit Objectives

At the end of this unit, students will be able to:

1. Discuss the concept of entrepreneurship
2. Discuss the importance of entrepreneurship
3. Describe the characteristics of an entrepreneur
4. Describe the different types of enterprises
5. List the qualities of an effective leader
6. Discuss the benefits of effective leadership
7. List the traits of an effective team
8. Discuss the importance of listening effectively
9. Discuss how to listen effectively
10. Discuss the importance of speaking effectively
11. Discuss how to speak effectively
12. Discuss how to solve problems
13. List important problem solving traits
14. Discuss ways to assess problem solving skills
15. Discuss the importance of negotiation
16. Discuss how to negotiate
17. Discuss how to identify new business opportunities
18. Discuss how to identify business opportunities within your business
19. Understand the meaning of entrepreneur
20. Describe the different types of entrepreneurs
21. List the characteristics of entrepreneurs
22. Recall entrepreneur success stories
23. Discuss the entrepreneurial process
24. Describe the entrepreneurship ecosystem

Notes for Facilitation

1. Ensure all the required material and equipment related to session is in place and in proper working condition before starting the session.
2. Before beginning the session, ask the students about what they learnt in the last session.
3. Explain the Objectives of the current session.
4. Use power point presentation to describe the topic.
5. Give assignment to measure the student understanding of the topic
6. Ensure that the session plan should be followed according to time duration to complete the course in-time.
7. Discuss the assignment questions with the students and provide correct answers.
8. At the end of the session summarize the key learning.

Ask



- What is entrepreneurship ?
- What make a good entrepreneurship ?
- What is a LLP ?
- How is reinvention important ?
- What are two elements of problem solving ?
- What is SWOT analysis ?
- Name two types of entrepreneurs.
- What is make in India campaign ?
- What is risk appetite

Unit 6.6: Preparing to be an Entrepreneur

Unit Objectives

At the end of this unit, students will be able to:

1. Discuss how market research is carried out
2. Describe the 4 Ps of marketing
3. Discuss the importance of idea generation
4. Recall basic business terminology
5. Discuss the need for CRM
6. Discuss the benefits of CRM
7. Discuss the need for networking
8. Discuss the benefits of networking
9. Understand the importance of setting goals
10. Differentiate between short-term, medium-term and long-term goals
11. Discuss how to write a business plan
12. Explain the financial planning process
13. Discuss ways to manage your risk
14. Describe the procedure and formalities for applying for bank finance
15. Discuss how to manage your own enterprise
16. List important questions that every entrepreneur should ask before starting an enterprise

Notes for Facilitation

1. Ensure all the required material and equipment related to session is in place and in proper working condition before starting the session.
2. Before beginning the session, ask the students about what they learnt in the last session.
3. Explain the Objectives of the current session.
4. Use power point presentation to describe the topic.
5. Give assignment to measure the student understanding of the topic
6. Ensure that the session plan should be followed according to time duration to complete the course in-time.
7. Discuss the assignment questions with the students and provide correct answers.
8. At the end of the session summarize the key learning.

Ask

- What are the 4 Ps ?
- What is Depreciation ?
- What is ROI ?
- Why is networking important ?
- How will one set goals ?
- What is business plan ?
- What are channels of distribution ?
- What documents must be prepared for loans ?
- What is seed funding ?

Annexure I

Training Delivery Plan

Training Delivery Plan			
Program Name:	Wire saw Operator		
Qualification Pack Name & Ref. ID	MIN/Q 0203		
Version No.	1.1	Version Update Date	24/03/2017
Pre-requisites to Training (if any)	Preferably class XII (Suggested but not mandatory) <ol style="list-style-type: none"> 1. Technical and gallery training as per First schedule, Mining vocational training rules (MVTR 1966) 2. Operator training for Wire saw 		
Training Outcomes	By the end of this program, the participants will be able to: <ol style="list-style-type: none"> 1. Understand the wire saw machine and its types. 2. Operate a wire saw machine which is used to cut large blocks of stone out from the marble quarry. 3. Apply health and safety measures in terms of personal safety and understanding of safety and precaution of wire saw machine. 4. Follow the regulatory guidelines on health & safety framed by DGMS. 5. Identify and use basic tools, equipment & materials used in operation of wire saw machine. 6. Understand health and safety measures required at Mine site. 		

Sl. No	Module Name	Session Name	Session Objectives	NOS Reference	Methodology	Training Tools/Aids	Duration
1.	Introduction	Icebreaker	<ul style="list-style-type: none"> • How to introduce each other • When to build rapport with fellow students and the facilitator 		Group Activity: Passing the parcel	Available objects such as pen, book etc	0.5 hours
2.	Introduction	Introduction to mining Industry	<ul style="list-style-type: none"> • Compare different types of mines and detail of the mine he is working in • Explain about mine Organization, time keeping, need for 	MIN/N 0209 KA5, KA6, KA7, KA8, KA9	<ul style="list-style-type: none"> • Field Visit • Demonstration • Team activity 	Sample of different minerals, India map showing mining area	3 hours

			<p>discipline and punctuality</p> <ul style="list-style-type: none"> • Illustrate benching in quarries, Dressing of overhangs, undercuts, Fencing, First aid and Hygiene • Outline the code of traffic in specific areas of mine. Significance of fences • Explain the standing orders in force at the mine. Safety in the vicinity of machinery 	<p>MIN/N 0210 KA1, KA2, KA3, KA4, KA5</p> <p>MIN/N 0211 KA7, KA8, KA9, KA10, KA11</p> <p>MIN/N 0204 KA1, KA3, KA4</p>	Lecture based training	<p>1. Personal protective equipment- shoes, helmet, dust mask, reflective jacket</p> <p>2. Wire saw machine</p> <p>3. Spanner</p> <p>4. Gang Saw</p> <p>5. Diamond chain saw</p> <p>Laptop, projector, colour pen, white board</p>	1 hours
3.	Introduction	Mining Methods stone mining	<ul style="list-style-type: none"> • Explain shot-firing and Safety regulations. How and where to take shelter • Demonstrate tramways and siding, Haulage rooms, Winding rooms, Boilers, Electrical Gears • Define duties of workmen under Mines act • Tell the provision of wages, working hours and accident compensation as per Mines act • Illustrate the mining safety procedures • Relate Outcome of violation of safely procedures 	<p>MIN/N 0209 KA10, KA11, KA12, KA13, KA14, KA15, KA16, KA17</p> <p>MIN/N 0210 KA6, KA7, KA8, KA9, KA10, KA11, KA12, KA13</p> <p>MIN/N 0211 KA12, KA13, KA14, KA15, KA16, KA17, KA18, KA19</p>			2 hours

4.		Mining equipment & tools used	<ul style="list-style-type: none"> Explain the precautions to be taken when handling heavy equipment Cover the refresher training as per fourth schedule MVTR (1966) within one month of joining duties following absence from duties for a period exceeding one year. 	MIN/N 0204 KA5, KA6, KA7	Field visit		3 hours
5.			<ul style="list-style-type: none"> Explain basic electricity Illustrate duties & responsibility of wire-saw operator 		Lecture based training	Laptop, projector, colour pen, white board	1.5 hours
6.	Prepare Wire saw	Introduction to wire saw	<ul style="list-style-type: none"> Define the common terminology vis-à-vis Wire sawing Demonstrate the different types of Wire saws and their specific use Elaborate Specification and details of blast hole Wire saws used in open-cast mines Explain the instrument panel, various controls their location and operation 	MIN/N 0209 KB7, KB1, KB2, KB3 MIN/N 0210 KB1, KB4, KB8	Lecture based training	Laptop, projector, colour pen, white board	2 hours
					<ul style="list-style-type: none"> Demonstration Field visit 	<ol style="list-style-type: none"> Personal protective equipment-shoes, helmet, dust mask, reflective jacket Wire saw machine Spanner Gang Saw Diamond chain saw 	4 hours
7.			<ul style="list-style-type: none"> Summarise manufacturer's instructions which apply to the care and safe operation of the wire saw 	MIN/N 0209 Pc8			2 hours
8.	Prepare Wire saw	Inspection of site work	<ul style="list-style-type: none"> Why routine checks essential before starting Wire saw operations 	MIN/N 0209 Kb8, PC2, Pc3	<ul style="list-style-type: none"> Lecture based training 	Laptop, projector, colour pen, white board	2 hours

			<ul style="list-style-type: none"> • Discuss why crown blocks are mounted securely 		<ul style="list-style-type: none"> • Demonstration 	<ol style="list-style-type: none"> 1. Personal protective equipment-shoes, helmet, dust mask, reflective jacket 2. Wire saw machine 3. Spanner 4. Gang Saw 5. Diamond chain saw 	4 hours
9.	Prepare Wire saw	Inspection of oil & Lubrication	<ul style="list-style-type: none"> • List the various controls, gauges, warning lamp and other safety devices 	MIN/N 0209 Kb4	<ul style="list-style-type: none"> • Demonstration 	<ol style="list-style-type: none"> 1. Personal protective equipment-shoes, helmet, dust mask, reflective jacket 2. Wire saw machine 3. Spanner 4. Gang Saw 5. Diamond chain saw 	6 hours
10.	Prepare Wire saw	Preparation before operation	<ul style="list-style-type: none"> • How to check hose connections are in order, if using a compress air Wire saw • How to check that Wire sawing equipment is in safe operating condition. • Explain greasing to all greasing pins and pivot points • Name the various levers and switches in order to operate the Wire saw properly • What are the different types of Wire saw bits and their uses 	MIN/N 0209 PC4, PC5, PC6, Pc2	<ul style="list-style-type: none"> • Demonstration 	<ol style="list-style-type: none"> 1. Personal protective equipment-shoes, helmet, dust mask, reflective jacket 2. Wire saw machine 3. Spanner 4. Gang Saw 5. Diamond chain saw 	6 hours
11.	Perform Wire saw	Reporting to supervisor	<ul style="list-style-type: none"> • How to insure that the wire sawing site is clear of other mine workers to avoid any 	MIN/N 0209 Pc7, PC8, Pc1	<ul style="list-style-type: none"> • Lecture based training 	Laptop, projector, colour pen, white board	2 hours

			<p>accidents.</p> <ul style="list-style-type: none"> List rules and regulations of mine as per standard operating procedure (SOP) What are the risk and impact of not following company's SOP Explain duties and responsibilities 	<p>MIN/N 0210 MIN/N 0211 KB3, KB4, KB6</p>	<ul style="list-style-type: none"> Demonstration 	<ol style="list-style-type: none"> Personal protective equipment-shoes, helmet, dust mask, reflective jacket Wire saw machine Spanner Gang Saw Diamond chain saw 	
12.	Perform Wire saw Operations	Understanding operating standards	<ul style="list-style-type: none"> Show the plan and organizing the job according to the site engineer instructions Describe organize daily consumables according to the day's plan 	<p>MIN/N 0210 PC1, PC2</p>	<ul style="list-style-type: none"> Lecture based training On the job training 	<p>Laptop, projector, colour pen, white board</p>	<p>4 hours</p> <p>8 hours</p>
13.	Perform Wire saw Operations	Familiarisation of control panel	<ul style="list-style-type: none"> How to operate propelling motor control levers for smoothly moving the wire saw machine in all four directions 	<p>MIN/N 0210 PC3</p>	<ul style="list-style-type: none"> Demonstration 	<ol style="list-style-type: none"> Personal protective equipment-shoes, helmet, dust mask, reflective jacket Wire saw machine Spanner Gang Saw Diamond chain saw 	
14.	Perform Wire saw Operations	Do & Don't of wiresaw	<ul style="list-style-type: none"> Ensure all necessary precautions are adhered to before towing the Wire saw to a distant site. Do & don't of wiresaw. 	<p>MIN/N 0210 PC3</p>	<ul style="list-style-type: none"> Lecture based training Demonstration 	<p>Laptop, projector, colour pen, white board</p>	<p>4 hours</p> <p>8 hours</p>

15.	Perform Wire saw Operations	Operation of wiresaw	<ul style="list-style-type: none"> How you can raise Wire saw guide to 1.5m above ground level and make it horizontal to prevent any damage in transit 	MIN/N 0210 PC5	<ul style="list-style-type: none"> Demonstration 	<ol style="list-style-type: none"> Personal protective equipment-shoes, helmet, dust mask, reflective jacket Wire saw machine Spanner Gang Saw Diamond chain saw 	8 hours
16.	Perform Wire saw Operations	Work safety	<ul style="list-style-type: none"> Where to ensure a stable base for mounting the Wire saw Show how to adjust the tracks by methodically manipulating the positions of oscillation cylinder valve and hydraulic track valve. Why work area is barricaded or banded and erect signage as required to make work area safe 	MIN/N 0210 PC6, PC7, PC8	<ul style="list-style-type: none"> Demonstration 	<ol style="list-style-type: none"> Personal protective equipment-shoes, helmet, dust mask, reflective jacket Wire saw machine Spanner Gang Saw Diamond chain saw 	8 hours
17.	Perform Wire saw Operations	Typical Issues and trouble shooting	<ul style="list-style-type: none"> What are the basic maintenance steps such as replacing rubber on the pulleys, cleaning the diamond wire guard and drive wheel guard, keeping grip points free from oil and grease. 	MIN/N 0210 Kb15, KB16 Kb17	<ul style="list-style-type: none"> Demonstration 	<ol style="list-style-type: none"> Personal protective equipment-shoes, helmet, dust mask, reflective jacket Wire saw machine Spanner Gang Saw Diamond chain saw 	8 hours

18.	Perform Wire saw Operations	Enhancing productivity cost & delay analysis	<ul style="list-style-type: none"> • Discuss cost of equipment and loss for the company that results from damage of equipment • List the implications of delays in process to the company 	MIN/N 0209 KA3, KA4	• Lecture based training	Laptop, projector, colour pen, white board	1 hours
					• Demonstration	<ol style="list-style-type: none"> 1. Personal protective equipment-shoes, helmet, dust mask, reflective jacket 2. Wire saw machine 3. Spanner 4. Gang Saw 5. Diamond chain saw 	3 hours
19.	Perform Wire saw Operations	Sustainability	<ul style="list-style-type: none"> • How to ensure that the highest level of quality is consistently maintained • How to ensure that all associated products (couplings/rods etc.) are used to their maximum potential, while ensuring their sustainability 	MIN/N 0210 PC9, PC10	• Demonstration	<ol style="list-style-type: none"> 1. Personal protective equipment-shoes, helmet, dust mask, reflective jacket 2. Wire saw machine 3. Spanner 4. Gang Saw 5. Diamond chain saw 	8 hours
20.	Perform Wire saw Operations	Enhancing productivity by reducing downtime	<ul style="list-style-type: none"> • Tell how to reduce downtime and wastage • Demonstrate caution against hazards of Wire saw machine in operation associated with his job role as per the employer 	MIN/N 0210 PC11, PC12	• Demonstration	<ol style="list-style-type: none"> 1. Personal protective equipment-shoes, helmet, dust mask, reflective jacket 2. Wire saw machine 3. Spanner 4. Gang Saw 5. Diamond chain saw 	8 hours

21.	Perform Wire saw Operations	Operation of wiresaw	<ul style="list-style-type: none"> Discuss operation of different sub-assemblies such as drive wheel, hydraulic system, power unit, water supply system, wire tensioning arm, wire length adjustment pulley etc. Tell the specification and details of diamond wire saws used in open-cast mines 	MIN/N 0210 KB2, KB3	<ul style="list-style-type: none"> Demonstration 	<ol style="list-style-type: none"> Personal protective equipment-shoes, helmet, dust mask, reflective jacket Wire saw machine Spanner Gang Saw Diamond chain saw 	8 hours
22.	Perform Wire saw Operations	Do	<ul style="list-style-type: none"> Show setting up of the saw for various tasks - horizontal, vertical or flush cutting. 	MIN/N 0210 KB9	<ul style="list-style-type: none"> Demonstration 	<ol style="list-style-type: none"> Personal protective equipment-shoes, helmet, dust mask, reflective jacket Wire saw machine Spanner Gang Saw Diamond chain saw 	6 hours
23.	Perform Wire saw Operations	Do	<ul style="list-style-type: none"> Justify wire sawing pattern and sequence of operations 	MIN/N 0210 KB10	<ul style="list-style-type: none"> Demonstration 	<ol style="list-style-type: none"> Personal protective equipment-shoes, helmet, dust mask, reflective jacket Wire saw machine Spanner Gang Saw Diamond chain saw 	8 hours
24.	Perform Wire saw Operations	Do	<ul style="list-style-type: none"> Explain the method and significance of twisting the diamond wire before joining connectors. Show mounting of the water supply nozzle for cooling of the wire while cutting 	MIN/N 0210 KB11, KB12	<ul style="list-style-type: none"> Demonstration 	<ol style="list-style-type: none"> Personal protective equipment-shoes, helmet, dust mask, reflective jacket Wire saw machine Spanner Gang Saw Diamond chain saw 	6 hours

25.	Perform Wire saw Operations	Do	<ul style="list-style-type: none"> Choose the optimal speed of driving and cutting to ensure best results. Illustrate the use of various systems in the remote control unit to control the hydraulic oil flow rate, wire tension control, longitudinal advance control for cutting direction, potentiometer for speed adjustment 	MIN/N 0210 KB13, KB14	<ul style="list-style-type: none"> Demonstration 	<ol style="list-style-type: none"> Personal protective equipment-shoes, helmet, dust mask, reflective jacket Wire saw machine Spanner Gang Saw Diamond chain saw 	6 hours
26.	Perform Wire saw Operations	Ensuring safety	<ul style="list-style-type: none"> List safety during Wire sawing, marching and other operations Why working area must be cordoned off as flying pieces of rock can be dangerous. Comply with all company Quality, Health, Safety and Environment policies and Procedures 	MIN/N 0210 KB15, KB16, KB17	<ul style="list-style-type: none"> Lecture based training 	Laptop, projector, colour pen, white board	1 hours
					<ul style="list-style-type: none"> Demonstration 	<ol style="list-style-type: none"> Personal protective equipment-shoes, helmet, dust mask, reflective jacket Wire saw machine Spanner Gang Saw Diamond chain saw 	2 hours
27.	Carry out reporting and documentation	Writing Skills	<ul style="list-style-type: none"> Tell fill up documentation applicable to one's role Improve english and vernacular language with few pauses and a constant speed Read and understand manuals, health and safety instructions, memos etc Show ability to read from different sources - books, screens in machines, 	MIN/N 0211 SA1 MIN/N 0209, 210 SA1, SA2	<ul style="list-style-type: none"> Lecture based training Team activity 	Laptop, projector, colour pen, white board	3 hours

			<p>signage etc.</p> <ul style="list-style-type: none"> Show the various color codes, as per standard mining nomenclature 	<p>MIN/N 0211 SA2, SA3, SA4, SA5</p> <p>MIN/N 0209, 210 SA3, SA4, SA5</p>	<ul style="list-style-type: none"> 		
28.	Carry out reporting and documentation	Oral Communication (Listening and Speaking skills)	<ul style="list-style-type: none"> Relate the statements or information clearly so that others can hear and understand Classify and understand the main points of simple discussions Plan appropriately to any queries How to communicate with supervisor 	<p>MIN/N 0211 SA6, SA7, SA7, SA8, SA9</p> <p>MIN/N 0209, 210 SA6</p>	<ul style="list-style-type: none"> Team activity 		3 hours
29.	Carry out reporting and documentation	Recording and Documentation	<ul style="list-style-type: none"> Explain identify documentation to be completed relating to one's role Show details accurately using the appropriate format Complete all documentation within stipulated time. Organize that documents are available to all appropriate authorities to 	<p>MIN/N 0211 PC4, PC5, PC6, PC7 KA1, KA2,</p> <p>MIN/N 0209 PC9, KA1</p> <p>MIN/N 0210 KB1, KB2</p>	<ul style="list-style-type: none"> Demonstration 	<ol style="list-style-type: none"> Personal protective equipment-shoes, helmet, dust mask, reflective jacket Wire saw machine Spanner Gang Saw Diamond chain saw 	5 hours

30.	Carry out reporting and documentation	Reporting of problem/incidents	<ul style="list-style-type: none"> • Relate problems/incidents as applicable in a timely manner • When to report appropriate authority as laid down by the employer • Follow reporting procedures as prescribed by the employer • What are the escalation matrix for reporting identified problems • Inform supervisor of problems that are beyond scope of his role 	MIN/N 0211 PC1, PC2, PC3 MIN/N 0210 KB5 MIN/N 0209 KA2, PC10	<ul style="list-style-type: none"> • Demonstration 	1. Personal protective equipment-shoes, helmet, dust mask, reflective jacket 2. Wire saw machine 3. Spanner 4. Gang Saw 5. Diamond chain saw	6 hours
31.	Carry out reporting and documentation		<ul style="list-style-type: none"> • How to make decisions pertaining to the concerned area of work • Justify problems in day to day tasks • Summarize possible solution with the supervisor for problem solving • When to make decisions in emergency conditions • Discuss the instructions and work on areas of improvement identified • Classify complete assigned tasks with minimum supervision • How to complete the job within 	MIN/N 0209, 210, 211 SB1, SB4, SB5, SB6, SB7, SB8, SB9, SB10, SB11, SB12 209, 210	<ul style="list-style-type: none"> • Lecture based training 	Laptop, projector, colour pen, white board	8 hours

			<p>timelines and quality norms</p> <ul style="list-style-type: none"> • Make use of common sense and judgments during day to day basis • Make use of reasoning skills to identify and resolve basic problems • Plan intuition to detect any 				
32.	Carry out reporting and documentation	Plan and Organize	<ul style="list-style-type: none"> • Show how to plan and organize the work order and jobs • Show all process manuals so that sorting/ accessing information is easy accessing information is easy • Experiment with checking/maintenance logbook to record all activities performed before starting the Wire saw • Utilize the job specific documents e.g. daily maintenance checklist and importance of the same • List the risk and impact of not following defined procedures/work instructions 	<p>MIN/N 0211 SB2, SB3</p> <p>MIN/N 0209, 210 SB2, SB3</p>	<ul style="list-style-type: none"> • Lecture based training 	Laptop, projector, colour pen, white board	1 hours

33.	Health and Safety		<ul style="list-style-type: none"> Plan with occupational health and safety regulations adopted by the employer. Demonstrate work responsibly and carefully so as not to put the health and safety of self or others at risk. Contrast the work responsibly and safe as possible so as not to put the health and safety of self or others at risk, including members of the public 	MIN/N 0204 PC1, PC4, PC8	<ul style="list-style-type: none"> Lecture based training 	Laptop, projector, colour pen, white board	2 hours
34.	Health and Safety	Hazards of Mining	<ul style="list-style-type: none"> Compare locally prepared Emergency Preparedness / Disaster Management Plan. Discuss mining operations procedures with respect to materials handling and accidents Utilize the correct safety steps in case of fire, accident, major failure Compare signage, mining area signs and other safety and emergency signals Explain the response to emergencies such as fire, accident, major failure etc. 	MIN/N 0204 KA8, PC2, PC3 MIN/N 0209 KB9, KB10 MIN/N 0210 KB18, KB19	<ul style="list-style-type: none"> Lecture based training 	Laptop, projector, colour pen, white board	2 hours

35.	Health and Safety	Mine safety equipment	<ul style="list-style-type: none"> • Discuss the perform storage and transport of hazardous materials compliant with safety guidelines prescribed by DGMS. • Demonstrate careful practices in handling explosives and heavy machinery. • Identify characteristics of post-blast fumes and take necessary precautions. • List hazardous material safety and security rules and regulations as prescribed by DGMS. 	MIN/N 0204 PC5, PC9, PC10, KA11	• Lecture based training	Laptop, projector, colour pen, white board	2 hours
					• Demonstration	<ol style="list-style-type: none"> 1. Personal protective equipment-shoes, helmet, dust mask, reflective jacket 2. Wire saw machine 3. Spanner 4. Gang Saw 5. Diamond chain saw 	2 hours
36.	Health and Safety	Fire safety	<ul style="list-style-type: none"> • Comply with safety regulations and procedures in case of fire hazard. • How to operate various grades of fire extinguishers 	MIN/N 0204 PC6, PC7	• Lecture based training	Laptop, projector, colour pen, white board	1 hours
					• Demonstration	<ol style="list-style-type: none"> 1. Personal protective equipment-shoes, helmet, dust mask, reflective jacket 2. Wire saw machine 3. Spanner 4. Gang Saw 5. Diamond chain saw 	4 hours
37.	Health and Safety	Waste management & environment effect	<ul style="list-style-type: none"> • Show environmental impact of mining • Classify sources of dust, noise and vibration and measures to minimize 	MIN/N 0204 KA9, KA10	Lecture based training	Laptop, projector, colour pen, white board	1 hours

					Demonstration	1. Personal protective equipment-shoes, helmet, dust mask, reflective jacket 2. Wire saw machine 3. Spanner 4. Gang Saw 5. Diamond chain saw	4 hours
38.	Health and Safety	First Aid	<ul style="list-style-type: none"> List first aid and hygiene 	MIN/N 0204 KA2	<ul style="list-style-type: none"> Lecture based training 	Laptop, projector, colour pen, white board	1 hours
					<ul style="list-style-type: none"> Demonstration 	1. Personal protective equipment-shoes, helmet, dust mask, reflective jacket 2. Wire saw machine 3. Spanner 4. Gang Saw 5. Diamond chain saw	4 hours
39.	Employability & Entrepreneurship skills	Individual Intrinsic and External Core Development	<ul style="list-style-type: none"> Discuss the steps to prepare for an interview Discuss the steps to create an effective resume Discuss the most frequently asked interview questions Discuss how to answer frequently asked interview questions Discuss different workable terminology 		<ul style="list-style-type: none"> Explaining Demonstrating Collaboration Learning by teaching Quiz & Exams 	Laptop, projector, colour pen, white board	8 hours
		Digitalized Era Flashback					8 hours
		Financial Handles					8 hours
		Proceeding with Understanding Entrepreneurial Battle					8 hours
		Entrepreneurship In Depth					8 hours

Annexure II

Assessment Criteria

CRITERIA FOR ASSESSMENT OF TRAINEES

Assessment Criteria for Assistant Beauty Therapist	
Job Role	Wire Saw operator
Qualification Pack	MIN/Q0203
Sector Skill Council	Skill Council for Mining Sector

Sr. No.	Guidelines for Assessment
1	For assessment for each Qualification Pack will be created by the Sector Skill Council. Each Performance Criteria (PC) will be assigned marks proportional to its importance in NOS. SSC will also lay down proportion of marks for Theory and Skills Practical for each PC
2	The assessment for the theory part will be based on knowledge bank of questions created by the SSC
3	Individual assessment agencies will create unique question papers for theory part for each candidate at each examination/training centre (as per assessment criteria below)
4	Individual assessment agencies will create unique evaluations for skill practical for every student at each examination/training centre based on this criteria
5	To pass the Qualification Pack, every trainee should score a minimum of 50% in every NOS and overall 70% pass percentage in every QP
6	In case of successfully passing only certain number of NOS's, the trainee is eligible to take subsequent assessment on the balance NOS's to pass the Qualification Pack.

Assessment outcome (NOS Code and Description)	Assessment criteria (PC)	Total Marks	Out Of	Marks Allocation	
				Theory	Skills Practical
1. MIN/N 0209 (Prepare Wire saw)	PC1. Adhere to time limits given by supervisor	25	2	1	1
	PC2. Check the various controls, gauges, warning lamp and other safety devices		3	0	3
	PC3. Ensure that crown blocks are mounted securely		3	1	2

	PC4. Check all those connections are in order, if using a compress air Wire saw		3	1	2
	PC5. Check that Wire sawing equipment is in safe operating condition.		2	0	2
	PC6. Apply grease to all greasing pins and pivot points		2	0	2
	PC7. The Wire sawing site is clear of other		2	0	2
	mine workers to avoid any accidents.				
	PC8. Follow the manufacturer's instructions which apply to the care and safe operation of the Wire saw.		2	1	1
	PC9. Maintain a checking/maintenance logbook to record all activities performed before starting the Wire saw		3	1	2
	PC10. Inform supervisor of problems that are beyond scope of his role		3	2	1
		Total	25	7	18
2. MIN/N 0210 (Perform Wire saw Operations)	PC1. Plan and organize the job according to the site engineer instructions	25	2	1	1
	PC2. Organize daily consumables according to the day's plan		3	1	2
	PC3. Operate propelling motor control levers to smoothly move the Wire saw machine in all four directions.		2	0	2

	PC4. Ensure all necessary precautions are adhered to before towing the Wire saw to a distant site.		2	1	1
	PC5. Raise Wire saw guide to 1.5m above ground level and make it horizontal to prevent any damage in transit.		2	1	1
	PC6. Ensure a stable base for mounting the Wire saw		2	0	2
	PC7. Adjust the tracks by methodically manipulating the positions of oscillation cylinder valve and hydraulic track valve.		2	0	2
	PC8. Have work area barricaded or banded and erect signage as required to make work area safe.		2	1	1
	PC9. Ensure that the highest level of quality is consistently maintained		2	1	1
	PC10. Ensure all associated products (couplings/rods etc) are used to their maximum potential, while ensuring their sustainability		2	0	2
	PC11. Reduce downtime and wastage		2	1	1
	PC12. Demonstrate caution against hazards of Wire saw machine in operation.		2	1	1
		Total	25	8	17

3. MIN/N 0211 (Carry Out Reporting and Logging- Wire saw Operator)	PC1. Report problems/incidents as applicable in a timely manner	25	4	2	2
	PC2. Report to the appropriate authority as laid down by the employer		4	2	2
	PC3. Follow reporting procedures as prescribed by the employer		4	1	3
	PC4. Identify documentation to be completed relating to one's role		4	1	3
	PC5. Record details accurately using the appropriate format		4	1	3
	PC6. Complete all documentation within stipulated time.		5	3	2
		Total	25	10	15
4. MIN/ N0204 (Health and Safety)	PC1. Comply with occupational health and safety regulations adopted by the employer.	25	2	1	1
	PC2. Follow mining operations procedures with respect to materials handling and accidents		3	0	2
	PC3. Follow the correct safety steps in case of fire, accident, major failure		2	0	2
	PC4. Work responsibly and carefully so as not to put the health and safety of self or others at risk.		2	0	2

	PC5. Perform storage and transport of hazardous materials compliant with safety guidelines prescribed by DGMS.		3	1	2
	PC6. Comply with safety regulations and procedures in case of fire hazard.		2	1	1
	PC7. Operate various grades of fire extinguishers.		3	1	2
	PC8. Work responsibly and as safe and careful as possible so as not to put the health and safety of self or others at risk, including members of the public		3	1	2
	PC9. Demonstrate careful practices in handling explosives and heavy machinery.		3	2	1
	PC10. Identify characteristics of post-blast fumes and take necessary precautions.		2	1	1
		Total	25	9	16



Skill India

कौशल भारत - कुशल भारत



सत्यमेव जयते
GOVERNMENT OF INDIA
MINISTRY OF SKILL DEVELOPMENT
& ENTREPRENEURSHIP



N.S.D.C.
National
Skill Development
Corporation

Transforming the skill landscape

SCMS

Address: FIMI House, B-311, Okhla Industrial Area,
New Delhi - 110020, India

Email: scms@skillcms.com

Web: skillcms.in

Phone: 011-26814596

CIN No.: 00000000

Price: ₹



978-1-111-22222-45-7